



## The Large Commercial Yacht Code (LY3)

**Notice to all designers, builders, owners, operators, employers, crews, skippers, and Classification Societies.**

*This Notice should be read in conjunction with the Merchant Shipping (Vessels in Commercial Use for Sport or Pleasure) Regulations 1998<sup>2</sup>, as amended<sup>3</sup>.*

### PLEASE NOTE:-

Where this document provides guidance on the law it should not be regarded as definitive. The way the law applies to any particular case can vary according to circumstances - for example, from vessel to vessel and you should consider seeking independent legal advice if you are unsure of your own legal position.

### Summary

- This Notice provides the revised text of the MCA publication "The Large Commercial Yacht Code (LY2)", published in 2007. LY2 replaced the MCA publication "The Code of Practice for Safety of Large Commercial Sailing and Motor Vessels".
- The revised text is to be known as the Large Commercial Yacht Code (LY3).
- Both the original text and the revisions have been prepared in consultation with stakeholders.
- Stakeholders include all elements of the construction and operational sectors of the large yacht industry together with representatives of the Red Ensign Group.

### Introduction/ Background

- 1 In 1997, the Agency published, its Code of Practice for the Safety of Large Commercial Sailing and Motor Vessels (LY1), which provided a "Code" approach for vessels which were unsuited to the application of conventional Merchant Shipping Regulations.
- 2 LY1 was given statutory force by the Merchant Shipping (Vessels in Commercial Use for Sport or Pleasure) Regulations 1998.
- 3 The original Code provided that within five years of its coming into force, the text would be revised if necessary, by a standing committee.

<sup>1</sup> Amendments made to LY2 Edition 2 are detailed in Annex 7

<sup>2</sup> SI 1998 No:2771

<sup>3</sup> SI 2000 No:482, S1 2002 No:1473, SI 2005 No:2114

4 Since its original publication, LY1 has made a significant impression on a maritime

sector which previously found great difficulty in embracing conventional regulation.

- 5 LY1 enjoyed both national support and international recognition as a standard, breaking new ground both in its inception and methodology.
6. LY1 was notified to the International Maritime Organization (IMO) as the United Kingdom's equivalent provisions under the equivalence arrangements of the International Convention on Load Lines 1966, as amended; The International Convention on the Safety of Life at Sea 1974, as amended; and The International Convention on Standards of Training, Certification and Watchkeeping for Seafarers (STCW) 1978, as amended.
7. LY2 replaced the original Code under provisions of regulation 2(2) of the Merchant Shipping (Vessels in Commercial Use for Sport or Pleasure) Regulations 1998, as amended, and became effective in August 2005. This revision has taken place in consultation with the large yacht industry and all comments from a public consultation have been considered by Working Groups comprising of experts from the international large yacht industry.
8. IMO disseminated the UK notification of "equivalent" provision in their Circular Letter No 1996, later replaced by No 2937.

#### **The Revised Codes**

9. This notice sets out the text of The Large Commercial Yacht Code (LY3) which replaces The Large Commercial Yacht Code (LY2).
10. The Code applies to motor or sailing vessels of 24 metres in load line length and over or, if built before 21 July 1968, which are of 150 tons gross tonnage and over and which, at the time, is in commercial use for sport or pleasure and which carries no cargo and no more than 12 passengers.
11. The Code only applies to vessels of less than 3000GT.
12. Sail training vessels are included in this application.
13. The provisions of LY3 require standards of safety and pollution prevention, which are appropriate to the size of the vessel. The standards are set by the relevant international conventions, and equivalent standards are applied where it is not reasonable or practicable to comply with international conventions.

#### **Further Information**

14. Further information on the contents of this Notice can be obtained from the address at the end of this Notice.
15. Effective date of implementation of LY3 is that of publication.

## More Information

### Vessel Policy Branch (Codes)

Maritime and Coastguard Agency  
Spring Place  
105 Commercial Road  
Southampton  
SO15 1EG

Tel : +44 (0) 23 8032 9139  
Fax : +44 (0) 23 8032 9104  
e-mail: [codes@mcga.gov.uk](mailto:codes@mcga.gov.uk)

General Inquiries: 24 Hour Infoline  
[infoline@mcga.gov.uk](mailto:infoline@mcga.gov.uk)  
0870 600 6505

MCA Website Address: [www.mcga.gov.uk](http://www.mcga.gov.uk)

File Ref: MSA 010 / 009 / 0184

Published: **Date**

© Crown Copyright 2011

**Safer Lives, Safer Ships, Cleaner Seas**

*Printed on material containing minimum 75% post-consumer waste paper*



*An executive agency of the  
Department for  
**Transport***

## **LARGE COMMERCIAL YACHT CODE**

Large means 24 metres and over in load line length and the Code of Practice applies to yachts which are in commercial use for sport or pleasure, do not carry cargo and do not carry more than 12 passengers.

## TABLE OF CONTENTS

1	FOREWORD .....	8
2	DEFINITIONS .....	10
3	APPLICATION AND INTERPRETATION .....	18
4	CONSTRUCTION AND STRENGTH .....	21
5	WEATHERTIGHT INTEGRITY .....	24
6	WATER FREEING ARRANGEMENTS .....	30
7A	MACHINERY- VESSELS OF LESS THAN 500GT .....	32
7B	MACHINERY- VESSELS OF 500GT AND OVER .....	33
8A	ELECTRICAL INSTALLATIONS - VESSELS OF LESS THAN 500GT . . . .	34
8B	ELECTRICAL INSTALLATIONS - VESSELS OF 500GT AND OVER . . . .	35
9A	STEERING GEAR - VESSELS OF LESS THAN 500GT .....	36
9B	STEERING GEAR - VESSELS OF 500GT AND OVER .....	37
10A	BILGE PUMPING - VESSELS OF LESS THAN 500GT .....	38
10B	BILGE PUMPING - VESSELS OF 500GT AND OVER .....	39
11	STABILITY .....	40
12	FREEBOARD .....	49
13	LIFE SAVING APPLIANCES .....	51
14	FIRE SAFETY .....	59
14A	STRUCTURAL FIRE PROTECTION - VESSELS OF LESS THAN 500GT . .	63
14B	STRUCTURAL FIRE PROTECTION - VESSELS OF 500GT AND OVER . . .	70
15A	FIRE APPLIANCES - VESSELS OF LESS THAN 500GT .....	89
15B	FIRE APPLIANCES - VESSELS OF 500GT AND OVER .....	94
16	RADIO .....	95
17	NAVIGATION LIGHTS, SHAPES AND SOUND SIGNALS .....	98
18	NAVIGATIONAL EQUIPMENT AND VISIBILITY FROM WHEELHOUSE .....	99
19	MISCELLANEOUS EQUIPMENT .....	101
20	ANCHORS AND CABLES .....	102
21	ACCOMMODATION .....	103

22	PROTECTION OF PERSONNEL .....	106
23	MEDICALSTORES .....	109
24	SHORE-SHIPTRANSFER OF PERSONNEL .....	110
25	CLEAN SEAS .....	113
26	MANNING AND PERSONNEL CERTIFICATION .....	114
27	PASSENGERS .....	122
28	SURVEY, CERTIFICATION, INSPECTION AND MAINTENANCE ... ..	123
29	CREW AGREEMENTS .....	126
30	SAFETY MANAGEMENT .....	127
31	INTERNATIONAL SHIP AND PORT FACILITY SECURITY CODE .....	128
ANNEX 1	MEMBER'S OF THE STEERING COMMITTEE AND WORKING GROUP ..	129
	RESPONSIBLE FOR THE CODE	
ANNEX 2	SAFETY MANAGEMENT SYSTEM FOR VESSELS UNDER 500GT .....	130
ANNEX 3	OPEN FLAME GAS INSTALLATIONS .....	134
ANNEX 4	LIST OF CERTIFICATES TO BE ISSUED .....	137
ANNEX 5	UNITED KINGDOM NATIONAL ANNEX .....	138
ANNEX 6	TECHNICAL STANDARDS FOR HELICOPTER LANDING AREAS .....	145
ANNEX 7	AMENDMENTS TO THE TEXT OF MSN 1792 LY2 <b>EDITION 2</b> .....	146

# 1 FOREWORD

This Code of Practice has been developed jointly by the United Kingdom, its relevant overseas territories **and crown dependencies**, and international industry representatives.

1.1 Where "Administration" is used in the Code, it means the Government of the State whose flag the ship is entitled to fly.

1.2 Vessels are required to comply with the various merchant shipping regulations of the Administration which are relevant to the class of vessel to which they belong. Vessels in commercial use for sport or pleasure do not fall naturally into a single class and, in any case, prescribed merchant ship safety standards may be incompatible with the safety needs particular to such vessels.

1.3 The Code applies to vessels of less than 3000 gross tonnes (GT) in commercial use for sport or pleasure (being pleasure vessels "engaged in trade" for the purpose of Article 5 Exceptions - of the International Convention on Load Lines, 1966 (ICLL)) which are 24 metres in load line length and over or, if built before 21 July 1968, 150 gross tons and over according to the tonnage measurement regulations applying at that date and which do not carry cargo and do not carry more than 12 passengers.

1.4 The United Kingdom has notified the International Maritime Organization of the Code and its application to pleasure vessels engaged in trade as an equivalent arrangement under the provisions of Article 8 of the International Convention on Load Lines, 1966, Regulation I-5 of the International Convention on Safety of Life at Sea, and Article 9 of the International Convention on Standards of Training Certification and Watchkeeping for Seafarers 1978 as amended. Reference can be made to IMO Circular Letter No. **2937, dated 13 January 2009**.

1.5 The Code sets required standards of safety and pollution prevention which are appropriate to the size of the vessel. The standards applied are either set by the relevant international conventions or equivalent standards where it is not reasonable or practicable to comply. Provision is made within the Code to add any specific national requirements within a National Annex.

An Administration may consider a specific alternative equivalent standard to any standard required by the Code. Applications which justify either an alternative or exemption from a specific requirement of the Code can be made to the Administration.

1.6 The Code has been developed by an industry wide group with the express intention of setting pollution prevention and safety standards which identify with the specific needs of vessels in commercial use for sport and pleasure. The Code was reviewed and revised in 2004 to bring it up to date and reflect the needs of the industry. The standards adopted are judged to be at least equivalent in their effect to those required by the international conventions which apply to a particular vessel.

The membership of the industry wide groups that developed and revised the Code are listed in Annex 1.

1.7 Compliance with the standards required by the Code will entitle a vessel to be issued with the certification required by the international conventions applicable to the vessel, upon satisfactory completion of the corresponding surveys and inspections.

The certificates demanded by the international conventions which apply to the vessels covered by the Code are summarised in Section 28.

1.8 When equipment manufactured in accordance with a recognised British, European or International standard is required by the Code, the Administration may accept existing equipment which can be shown to be of an equivalent standard and which does not increase the risk to the ship or its crew and passengers. When such equipment is replaced, the replacement should conform to the standard required by the Code.

1.9 For vessels entitled to fly the flag of a Member State of the European Union, the Commission of the European Communities' general mutual recognition clause should be accepted. The clause states:

Any requirement for goods or materials to comply with a specified standard should be satisfied by compliance with:

- .1 a relevant standard or code of practice of a national standards body or equivalent body of a Member State of the European Community; or
- .2 any relevant international standard recognised for use in any Member State of the European Community; or
- .3 a relevant specification acknowledged for use as a standard by a public authority of any Member State of the European Community; or
- .4 traditional procedures of manufacture of a Member State of the European Community, and Turkey, where these are the subject of a written technical description sufficiently detailed to permit assessment of the goods or materials for the use specified; or
- .5 a specification sufficiently detailed to permit assessment for goods or materials of an innovative nature (or subject to innovative processes of manufacture such that they cannot comply with a recognised standard or specification) and which fulfil the purpose provided by the specified standard;

provided that the proposed standard, code of practice, specification or technical description provides, in use, equivalent levels of safety, suitability and fitness for purpose. Due attention should be paid to the requirements of the Marine Equipment Directive.

1.10 It is recognised that the Code may be required to be revised in the light of experience gained in its application. Section 3.4 makes provision for this.

1.11 It is recommended that pleasure vessels comply with the standards of the Code.

**DEFINITIONS**

(Note – where a definition is not contained within this Code, guidance should be taken from meanings given within the International Conventions)

"Administration" with regard to this Code means the Government of the State whose flag the ship is entitled to fly,

"Aiming Circle" (Touchdown/positioning marking) The aiming point for a normal landing, so designed that the pilot's seat can be placed directly above it in any direction with assured main and tail rotor clearances.

"Approved" in respect to materials or equipment means approved by the Administration or approved by an administration or organisation which is formally recognised by the Administration.

"Authorised surveyor" means a surveyor who by reason of professional qualifications, practical experience and expertise is authorised by the Administration to carry out the survey required for the vessel.

"Aviation Inspection Body" Body delegated the responsibility of inspecting helicopter landing areas by the Administration. The verification process will include inspection, certification and, where necessary, the application of appropriate operational limitations.

"Buoyant lifeline" means a line complying with the requirements of the IMO International Life-Saving Appliances Code.

"Cargo" means an item(s) of value that is carried from one place and discharged at another place and for which either a charge or no charge is made and is not for use exclusively onboard the vessel.

"Commercial vessel" means a vessel which is not a pleasure vessel.

"Control stations" are those spaces in which the ship's radio or main navigating equipment or the emergency source of power are located or where the fire recording or fire control equipment is centralized.

"D-Value" The largest overall dimension of the helicopter when rotors are turning. This dimension will normally be measured from the most forward position of the main rotor tip path plane to the most rearward position of the tail rotor tip path plane (or the most rearward extension of the fuselage in the case of Fenestron or Notar tails).

"D-Circle" A circle, usually imaginary unless the helicopter landing area itself is circular, the diameter of which is the D-Value of the largest helicopter the landing area is intended to serve. This will not be the case for landing areas of less than 1D width. For landing areas of less than 1D width, the edges of the imaginary D circle, may extend beyond the edge of the load bearing area by up to 0.085D on either side at the mid point.

"Efficient" in relation to a fitting, piece of equipment or material means that all reasonable and practicable measures have been taken to ensure that it is suitable for the purpose for which it is intended to be used.

"Embarkation ladder" means a ladder complying with the requirements of the IMO International Life-Saving Appliances Code.

"Emergency source of electrical power" is a source of electrical power, intended to supply the emergency switchboard in the event of failure of the supply from the main source of electrical power.

"Emergency switchboard" is a switchboard which in the event of failure of the main electrical power supply system is directly supplied by the emergency source of electrical power or the transitional source of emergency power and is intended to distribute electrical energy to the emergency services.

"EPIRB" means a satellite emergency position-indicating radio beacon, being an earth station in the mobile-satellite service, the emissions of which are intended to facilitate search and rescue operations, complying with performance standards adopted by the IMO contained in either Resolution A.810(19) or Resolution A.812(19) and Resolution A.662(16), or any Resolution amending or replacing these from time to time and which is considered by the Administration to be relevant, and is capable of:

- (a) floating free and automatically activating if the ship sinks;
- (b) being manually activated; and
- (c) being carried by one person;

"Existing vessel" means any vessel, the keel of which was laid or the construction or lay up was started before the 16th December 1998.

"Float-free launching" means that method of launching a liferaft whereby the liferaft is automatically released from a sinking ship and is ready for use, complying with the requirements of the IMO International Life-Saving Appliances Code.

"FOD" Foreign Object debris

"Freeboard" has the meaning given in annex I of ICLL. The freeboard assigned is the distance measured vertically downwards amidships from the upper edge of the deck line to the upper edge of the related load line.

"Freeboard deck" has the meaning given in annex I of ICLL. The freeboard deck is normally the uppermost complete deck exposed to the weather and sea, which has permanent means of closing all openings in the weather part thereof, and below which all openings in the sides of the ship are fitted with permanent means of watertight closing.

In a ship having a discontinuous freeboard deck, the lowest line of the exposed deck and the continuation of that line parallel to the upper part of the deck is taken as the freeboard deck.

At the option of the owner and subject to the approval of the Administration, a lower deck may be designated as the freeboard deck provided it is a complete and permanent deck continuous in a fore and aft direction at least between the machinery space and peak bulkheads and continuous athwart ships.

When a lower deck is designated as the freeboard deck, that part of the hull which extends above the freeboard deck is treated as a superstructure so far as concerns the application of the conditions of assignment and the calculation of freeboard. It is from this deck that the freeboard is calculated.

"Garbage" means all kinds of victual, domestic and operational waste excluding fresh fish and parts thereof, generated during the normal operation of the vessel and liable to be disposed of continuously or periodically, except sewage originating from vessels.

"Hazardous space" means a space or compartment in which combustible or explosive gases or vapours are liable to accumulate in dangerous concentrations.

"ICAO" International Civil Aviation Organization.

"ICLL" means the International Convention on Load Lines, 1966, as amended.

"IMO" means the International Maritime Organisation, a specialised agency of the United Nations devoted to maritime affairs.

"Inflatable lifejacket" means a lifejacket complying with the requirements of the IMO International Life-Saving Appliances Code.

"Jet A1 Fuel" Also known as kerosene. It is used as a fuel for modern jet and turboprop engines. It consists primarily of hydrocarbon compounds, but other additives are present to increase safety. International regulations stipulate uniform standards for the quality and composition of kerosene.

"Landing Area" A generic term referring to any area primarily intended for the landing or take-off of aircraft.

"Instructions for on-board maintenance" means the instructions complying with the requirements of SOLAS III/Part B – Life Saving Appliances and Arrangements, Regulation 36.

"Launching appliance" means a provision complying with the requirements of the IMO International Life-Saving Appliances Code for safely transferring a lifeboat, rescue boat, or liferaft respectively, from its stowed position to the water and recovery where applicable.

"Length" means 96% of the total length on a waterline of a ship at 85% of the least moulded depth measured from the top of the keel, or the length from the fore-side of the stem to the axis of the rudder stock on that waterline, if that be greater. In ships designed with a rake of keel the waterline on which this is measured shall be parallel to the designed waterline.<sup>1</sup>

"Lifeboat" means a lifeboat complying with the requirements of the IMO International Life-Saving Appliances Code.

"Lifebuoy" means a lifebuoy complying with the requirements of the IMO International Life-Saving Appliances Code.

"Lifejacket" means a lifejacket complying with the requirements of the IMO International Life-Saving Appliances Code.

"Liferaft" means a liferaft complying with the requirements of the IMO International Life-Saving Appliances Code;

"Line throwing appliance" means an appliance complying with the requirements

---

<sup>1</sup> The UK definition of length is contained in Statutory Instrument 1998 No. 2241 The Merchant Shipping (Load line) Regulations 1998, as amended.

of the IMO International Life-Saving Appliances Code.

"LOS" Limited Obstacle Sector. The 150° sector within which obstacles may be permitted, provided the height of the obstacles is limited.

"Low flame spread" means that the surface thus described will adequately restrict the spread of flame, this being determined to the satisfaction of the Administration by an established procedure.

"Machinery spaces" are all machinery spaces of category A and all other spaces containing propelling machinery, boilers, oil fuel units, steam and internal combustion engines, generators and major electrical machinery, oil filling stations, refrigerating, stabilizing, ventilation and air conditioning machinery, and similar spaces, and trunks to such spaces.

"Machinery spaces of category A" are those spaces and trunks to such spaces which contain:

- (a) internal combustion machinery used for main propulsion; or
- (b) internal combustion machinery used for purposes other than main propulsion where such machinery has in the aggregate a total power output of not less than 375Kw; or
- (c) any oil-fired boiler or oil fuel unit.

"Main source of electrical power" is a source intended to supply electrical power to the main switchboard for distribution to all services necessary for maintaining the ship in normal operation and habitable condition.

"Main switchboard" is a switchboard which is directly supplied by the main source of electrical power and is intended to distribute electrical energy to the ship's services.

"Main vertical zone" means those sections into which the hull, superstructure and deckhouses are divided by A class divisions, the mean length of which on any deck does not normally exceed 40 metres.

"MARPOL" means the International Convention for the Prevention of Pollution from Ships, 1973, as amended.

**"Major conversion" means a conversion of a vessel:**

- (a) that substantially alters the dimensions of a vessel, example: lengthening by adding new midbody;
- (b) which changes the type of the vessel;
- (c) the intent of which in the opinion of the Administration is substantially to prolong its life; example: renewal of passenger accommodation on one entire deck.
- (d) which otherwise so alters the ship that, if it were a new vessel, it would become subject to relevant provisions of the present code not applicable to it as an existing vessel.

"Maritime & Coastguard Agency" (MCA) means the Maritime & Coastguard Agency, an executive agency of the United Kingdom Department for Transport.

"Merchant Shipping Notice" (MSN) means a Notice described as such and

issued by the MCA and reference to a specific Merchant Shipping Notice includes reference to any Merchant Shipping Notice amending or replacing that Notice which is considered by the Secretary of State to be relevant from time to time and is specified in a Merchant Shipping Notice.

"Mile" means a nautical mile of 1852 metres.

"Motor vessel" means a vessel which is described in the register and on the certificate of registry as such, and which has a sole means of propulsion either one or more power units.

"Multihull vessel" means any vessel which in any normally achievable operating trim or heel angle, has a rigid hull structure which penetrates the surface of the sea over more than one separate or discrete area.

"New vessel" means a vessel to which this Code applies, the keel of which was laid or the construction or lay up was started on or after the 16th December 1998.

"Not readily ignitable" means that the surface thus described will not continue to burn for more than 20 seconds after removal of a suitable impinging test flame.

**"Officer" means**

- (a) any seafarer who is required to be qualified under the International Convention on Standards of Training, Certification and Watchkeeping for Seafarers, 1978, as amended (STCW Convention), or
- (b) any other seafarer considered by the owner/managing agent to be an officer.

"OFS" Obstacle-Free Sector. The 210° sector, extending outwards to a distance that will allow for an unobstructed departure path appropriate to the helicopter that the landing area is intended to serve, within which no obstacles above helideck level are permitted.

"Owner(s)/managing agent(s)" means the registered owner(s) or the owner(s) or the managing agent(s) of the registered owner(s) or the owner(s) or owner(s) ipso facto, as the case may be.

"Passenger" means any person carried in a ship except:

- (a) a person employed or engaged in any capacity on board the ship on the business of the ship;
- (b) a person on board the ship either in pursuance of the obligation laid upon the master to carry shipwrecked, distressed or other persons, or by reason of any circumstances that neither the master nor the owner nor the charterer (if any) could have prevented; and
- (c) a child under one year of age.

"Passenger ship" means a ship carrying more than 12 passengers.

"Person" means a person over the age of one year.

"Pleasure vessel" means a vessel so defined by the Administration (see National Annex).

"Position 1" means upon exposed freeboard and raised quarter decks, and upon

exposed superstructure decks situated forward of a point located a quarter of the ship's length from the forward perpendicular.

"Position 2" means upon exposed superstructure decks situated abaft a quarter of the ship's length from the forward perpendicular.

"Radar transponder" means a radar transponder for use in survival craft to facilitate location of survival craft in search and rescue operations.

"Recess" means an indentation or depression in a deck and which is surrounded by the deck and has no boundary common with the shell of the vessel.

"Rescue boat" means a boat complying with the requirements of the IMO International Life-Saving Appliances Code and designed to rescue persons in distress and for marshalling liferafts.

"Retro-reflective material" means a material which reflects in the opposite direction a beam of light directed on it.

"Rocket parachute flare" means a pyrotechnic signal complying with the requirements of the IMO International Life-Saving Appliances Code.

"Safe haven" means a harbour or shelter of any kind which affords entry, subject to prudence in the weather conditions prevailing, and protection from the force of the weather.

"Sailing vessel" means a vessel designed to carry sail, whether as a sole means of propulsion or as a supplementary means.

"Sail training vessel" means a sailing vessel which, at the time, is being used either:

- a) to provide instruction in the principles of responsibility, resourcefulness, loyalty and team endeavour and to advance education in the art of seamanship; or
- b) to provide instruction in navigation and seamanship for yachtsmen;

"Seafarer" means any person, including the master, who is employed or engaged or works in any capacity on board a ship on the business of the ship but does not include a person who-

- (a) is training in a sail training vessel, or
- (b) is onboard a sail training vessel other than for training but –
  - (i) [is not engaged in or responsible for the navigation of the vessels, and]
  - (ii) has no emergency safety responsibilities on the vessel.

"Self-activating smoke signal" means a signal complying with the requirements of the IMO International Life-Saving Appliances Code.

"Self-igniting light" means a light complying with the requirements of the IMO International Life-Saving Appliances Code.

"Short Range Yacht" means an existing vessel under 500GT or a new vessel under 300GT:

- restricted to operating in forecast or actual wind of a maximum Beaufort Force 4, **for a motor yacht, and Beaufort Force 6 for a sailing yacht;**
- within 60 nautical miles of a safe haven. (The Administration may permit operation on specified routes up to 90 nautical miles from a safe haven as appropriate);

**“Similar stage of construction” means at a stage which**

- (a) **construction identifiable with a specific vessel begins; and**
- (b) **assembly of that vessel, comprising at least 1% of the estimated mass of all structural material has commenced.**

**In the case of vessels constructed of FRP or GRP this will be considered as the date when more than 5% of the hull resin and reinforcement has been laid.**

“SLA” Safe Landing Area. The area bounded by the perimeter line and perimeter lighting. The construction of the OFS and LOS segments (see below) should ensure that the main rotor will not risk conflict with obstacles when the nose of the helicopter is butted-up to, but not projecting over, the perimeter line. Thus the pilot, when landing in unusual circumstances, has confidence that he can touch down provided that all wheels are within the SLA and the nose of the helicopter is not projecting over the nearest perimeter line ahead. However, only correct positioning over the aiming circle (see ‘Aiming Circle’ above) will ensure proper clearance with respect to physical obstacles, provision of ground effect, and provision of adequate passenger access/egress.

“SOLAS” means the International Convention of Safety of Life at Sea, 1974, as amended;

“SOLAS A pack” means a liferaft emergency pack complying with the requirements of the IMO International Life-Saving Appliances Code.

“SOLAS B pack” means a liferaft emergency pack complying with the requirements of the IMO International Life-Saving Appliances Code.

“Standard fire test” means a test in which specimens of the relevant bulkheads, decks or other constructions are exposed in a test furnace by a specified test method in accordance with the IMO Fire Test Procedures Code.

“Superstructure” has the meaning given in annex I to ICLL.

“Survival craft” means a craft capable of sustaining the lives of persons in distress from the time of abandoning the ship.

“Trainee”

A trainee **SHALL:**

1. Be engaged for the sole purpose of:
  - (a) Obtaining instruction in the principles of responsibility, resourcefulness, loyalty and team endeavour; and/or
  - (b) Instruction in navigation and seamanship, marine engineering or other shipboard related skills.

- 2 Be considered to form part of a 'trainee voyage crew'; and
- 3 Participate in the operation of the vessel to the best of his or her ability.

A trainee **SHALL NOT**:

- 1 Be part of the crew for the purpose of safe manning or have any safety critical duties;
- 2 Have any employment contract or any employment relationship with the owner or operator of the vessel;
- 3 Receive any remuneration for his/her activities on board;
- 4 Be considered to be a seaman or seafarer; and
- 5 Be considered as a passenger\*.

**\*Note** – the fact that a trainee(s) may contribute towards the cost of their welfare whilst on board should not imply that they are passengers.

The Minimum age of trainees shall be an issue for the National Marine Administration and requirements shall be as indicated in the National Annex.

Training organisations wishing to operate training vessels carrying more than 12 trainees shall comply with the requirements of the National Marine Administration as indicated in the National Annex.

"Training manual" with regard to life-saving appliances means a manual complying with the requirements of SOLAS III/Part B – Life Saving Appliances and Arrangements, Regulation 35.

"Training Vessel" Training Vessel which may be either a sailing or motor vessel, means a vessel which is operated to provide:

- a) Instruction in the principles of responsibility, resourcefulness, loyalty and team endeavour; and/or
- b) Instruction in navigation and seamanship, marine engineering or other shipboard related skills.

The vessel must be properly and safely manned at all times, both at sea and if necessary in port, by a sufficient number of experienced and competent personnel to ensure that trainees are adequately supervised giving particular consideration to the number, age and sex of the trainees.

All training shall be properly organised with clearly detailed objectives and outcomes.

"Two-way VHF radiotelephone set" means a portable or a fixed VHF installation for survival craft complying with the performance standards adopted by the IMO contained in A.762(18) or any Resolution amending or replacing it which is considered by the Administration to be relevant from time to time.

"Voyage" includes an excursion.

"Watertight" means capable of preventing the passage of water in any direction.

"Weather deck" means the uppermost complete weather tight deck fitted as an integral part of the vessel's structure and which is exposed to the sea and weather.

"Weathertight" has the meaning given in annex I of ICLL. Weathertight means that in any sea conditions water will not penetrate into the ship.

"Wheelhouse" means the control position occupied by the officer of the watch who is responsible for the safe navigation of the vessel.

"Window" means a ship's window, being any window, regardless of shape, suitable for installation aboard ships.

DISCLAIMER

### **3 APPLICATION AND INTERPRETATION**

#### **3.1 Application**

3.1.1 The Code applies to a motor or sailing vessel of 24 metres in load line length and over or, if built before 21 July 1968, which is of 150 tons<sup>2</sup> gross tonnage and over and which, at the time, is in commercial use for sport or pleasure and carries no cargo and no more than 12 passengers. The Code only applies to vessels of less than 3000GT. Sail training vessels are included in this application.

3.1.1.1 The administration may establish alternative standards for yachts operating under International Sailing Federation (ISAF) or Union Internationale Motonautique (UIM) racing rules.

3.1.2 Any provision of the Code expressed in the conditional (i.e. "should") shall be a requirement.

#### **3.1.3 Area of Operation**

3.1.3.1 In general, requirements given within the Code are based on unrestricted geographical operation however, where considered appropriate, standards for vessels operating as Short Range Yachts have been included.

3.1.3.2 Yachts which intend to operate within Polar regions must be classed accordingly. Structural strength, and systems incorporating heating and recirculation facilities should meet ice class standards. Stability considerations should include those for icing.

3.1.3.3 Reference to be made to the IMO Guidelines for Polar Regions, Resolution A.1024(26)

#### **3.2 Equivalent Standards, Exemptions and Existing Vessels**

##### **3.2.1 Equivalent standards**

Proposals for the application of alternative standards considered to be at least equivalent to the requirements of the Code should be submitted to the Administration for approval. Equivalence may be achieved by incorporating increased requirements to balance deficiencies and thereby achieve the overall safety standard.

##### **3.2.2 Exemptions**

Exemptions should be granted only by the Administration.

Applications for exemption should be made to the Administration and be supported by justification for the exemption.

The granting of exemptions will be limited by the extent to which international conventions allow and should be regarded as exceptional.

---

<sup>2</sup> "tons" means gross tons, measured in accordance with the Regulations for measuring tonnage in force on 20th July 1968

### 3.2.3 Existing vessels

3.2.3.1 In the case of an existing vessel which does not comply fully with the Code safety standards but for which the Code standards are reasonable and practicable, the Administration should give consideration to a proposal from the owner(s)/managing agent(s) to phase in requirements within an agreed time scale not exceeding 18 months.

3.2.3.2 When an existing vessel does not meet the Code safety standard for a particular feature and it can be demonstrated that compliance is neither reasonable nor practicable, proposals for alternative arrangements should be submitted to the Administration for approval. In considering individual cases, the Administration should take into account the vessel's service history and any other factors which are judged to be relevant to the safety standard which can be achieved.

3.2.3.3 Generally, repairs, alterations and refurbishments should comply with the standards applicable to a new vessel.

3.2.3.4 Existing vessels not previously certified under the Code **should be surveyed as follows:**

.1 Vessels whose surveys commenced before 1st June 2006 may be surveyed under LY1.

.2 Existing vessels under 500GT whose surveys commenced on or after 1st June 2006, should be surveyed under this Code. In such cases where engine room insulation does not meet the required standard, an alternative arrangement may be considered for short range service.

.3 Existing vessels of 500GT and over whose surveys commenced on or after 1<sup>st</sup> June 2006 but before 1st June 2008 may be certificated under LY1, providing:

(a) a sprinkler system is installed throughout all accommodation and service spaces, and

(b) an addressable fire detection system is installed throughout all accommodation and service spaces, and

(c) steps are taken to reduce the spread of smoke in accommodation escape routes.

.4 Existing vessels whose surveys commenced on or after [***the date of implementation of this Code***], should be surveyed under this Code.

.5 Existing vessels whose surveys commenced on or after [***the date of implementation of this Code***] but before [***the date of implementation of this Code + 2 years***] may be certified under LY2 Edition 2, providing:

(a) The additional lifejackets required by 13.2.7.2 are carried; and

(b) Vessels of 300GT and over meet the LRIT requirements of 18.1.8; and

(c) Vessels of 500GT and over are fitted with duplicate navigation

lights required by 17.3.

### 3.3 Interpretation

Where a question of interpretation of any part of this Code arises which cannot be resolved by a delegated authority and the owner(s)/managing agent(s) for a vessel, a decision on the interpretation may be obtained on written application to the Administration.

### 3.4 Updating the Code

The requirements of the Code will be reviewed and, if necessary revised, by the Administration in consultation with a standing committee. Any major revisions will be made in consultation with industry as listed at Annex 1.

### 3.5 Vessels Certified under "The Code of Practice for Safety of Large Commercial Sailing and Motor Vessels" (LY1) or "The Large Commercial Yacht Code" (LY2)

Vessels certified under "The Code of Practice for Safety of Large Commercial Sailing and Motor Vessels" (LY1) or "The Large Commercial Yacht Code" (LY2) may continue to be considered under the standards in force at the time of initial certification except that manning scales, for vessels under 500GT and compliance with section 29.2 (Safety Management) should comply with this Code (LY3).

[DRAFTING NOTE: Retrospective compliance to be further defined as per international carriage requirements]

Objective:- The purpose of this section is to ensure that all vessels are constructed to a consistent standard in respect of strength and watertight integrity. New Vessels are to be built to the requirements of one of the recognised Classification Societies listed in the National Annex and issued with a commercial Certificate of Classification. Existing Vessels which do not have a Certificate of Classification issued by a Classification Society listed in the National Annex should obtain such a certificate. For vessels under 500GT alternative arrangements for Short Range operation may be agreed by the Administration. The extent of the watertight bulkheads defined in Section 4.3, is to ensure that sufficient buoyancy is maintained by the vessel to meet the damaged stability requirements of Section 11.

#### 4.1 General Requirements

- 4.1.1 All vessels should have a freeboard deck.
- 4.1.2 All vessels should be fitted with a weather deck throughout the length of the vessel and be of adequate strength to withstand the sea and weather conditions likely to be encountered in the declared area(s) of operation.
- 4.1.3 The declared area(s) of operation and any other conditions which restrict the use of the vessel at sea should be recorded on the load line certificate issued to the vessel.
- 4.1.4 The choice of hull construction material affects fire protection requirements, for which reference should be made to section 14A and 14B.
- 4.1.5 Where a considerable risk of lightning strike is identified it is recommended that attention is paid to lightning strike protection

#### 4.2 Structural Strength

- 4.2.1 For unlimited operation, all vessels must be classed.
- 4.2.2 For operation within the Short Range Yacht Category, all new vessels must be classed.
- 4.2.3 Existing un-classed vessels of less than 500GT may be considered for restricted operation within the Short Range Category.
- 4.2.4 Attention should be paid to local or global hull strength requirements for the provision of ballast.

#### 4.3 Watertight Bulkheads

Section 11 of the Code deals with subdivision and damage stability requirements which will determine the number and positioning of watertight bulkheads defined below.

- 4.3.1 Watertight bulkheads should be fitted in accordance with the following requirements.
- .1 The strength of watertight bulkheads and their penetrations, and watertight integrity of the division should be in accordance with the

requirements of one of the Classification Societies referred to in the National Annex.

- .2 Generally, openings in watertight bulkheads should comply with the standards required for passenger vessels, as defined in SOLAS Chapter II-1. Hand operation from above the bulkhead deck and a hydraulic accumulator may be omitted if each door has its own hydraulic power-pack electrically driven via the emergency switchboard, and control voltage from emergency battery, and each door can be operated manually at the door by hand pump.
- .3 Approved hinged doors may be provided for infrequently used openings in watertight compartments, where a crew member will be in immediate attendance when the door is open at sea. Audible & visual alarms should be provided in the wheelhouse.
- .4 Unless otherwise required by section 4.4, watertight doors in yachts under 500GT may be approved hinged doors provided that there is an audible and visual alarm on the Bridge indicating when the door is open. The doors are to be kept closed at sea and marked accordingly. A time delay for the alarm is acceptable.
- .5 Procedures for the operation of watertight doors should be agreed with the administration and posted in suitable locations. Watertight doors should be normally closed, with the exception of sliding watertight doors providing the normal access to frequently used living and working spaces. Additionally when an access is unlikely to be used for lengthy periods, the door should also be closed. All watertight doors should be operationally tested before a ship sails and once a week.

#### **4.4 Enclosed Compartments within the Hull and below the Freeboard Deck provided with Access through Openings in the Hull**

4.4.1 **Compartment(s) below the freeboard deck, provided for recreational purposes, oil fuelling/fresh water reception or other purposes to do with the business of the vessel and having access openings in the hull, should be bounded by watertight divisions without any opening (i.e. doors, manholes, ventilation ducts or any other opening) separating the compartment(s) from any other compartment below the freeboard deck, unless provided with sliding watertight doors complying with 4.3.1, or for vessels under 500GT, hinged doors complying with 4.4.2.**

4.4.2 For vessels under 500GT, openings from any other compartment below the freeboard deck may be fitted with hinged watertight doors provided:

- .1 after flooding through the shell opening of the space containing the shell opening, the resultant waterline is below the sills of the internal openings in that space; or
- .2 (a) bilge alarms are fitted in the compartment containing the shell opening, with a visual and audible warning on the bridge; and  
(b) any hinged door opens into the compartment containing the shell opening; and  
(c) "open" door alarms, both visual and audible fitted on the bridge; and

- (d) the door is to be fitted with a single closing mechanism; and
- (e) sill height of the internal door should be higher above the design waterline than the sill height of the shell opening.

**4.4.3** Openings in the hull should comply with SOLAS regulation II-1/15-1 - External openings in cargo ships. Provision should be made to ensure that doors may be manually closed and locked in the event of power or hydraulic failure. **A minimum of 230mm should be provided between the deepest loaded waterline to the bottom edge of the opening. Alternative arrangements may be specially considered by the administration.**

## **4.5 Rigging on Sailing Vessels**

### **4.5.1 General**

**4.5.1.1** The condition of the rig should be monitored in accordance with a **Maintenance Manual and a** planned maintenance schedule. The schedule should include, in particular, regular monitoring of all the gear associated with safe work aloft and on the bowsprit (see 22.3).

### **4.5.2 Masts and spars and standing rigging**

**4.5.2.1** Dimensions and construction materials of masts and spars **and dimensions of standing rigging** should be in accordance with the requirements or recommendations of one of the Classification Societies referred to in 4.3.1.1 or a recognised national or international standard.

**4.5.2.2** The associated structure for masts and spars (including **chainplates**, fittings, decks and floors) should be constructed to effectively carry and transmit the forces involved.

**4.5.2.3** **Compliance with 4.5.2.1 and 4.5.2.2 shall be confirmed by a design review and approval by one of the Classification Societies (e.g. Rig Design Certificate) which is assigned with the review of the rig.**

**4.5.2.4** **The Maintenance Manual provided by the mast manufacturer shall be reviewed and approved by the Classification Society which is assigned to review the rig design.**

**4.5.2.5** **A physical survey on the rig stepping procedure and the rig behavior during sea trials is to be carried out by or on behalf of the Classification Society that is involved with the classification of the vessel's hull.**

**4.5.2.6** **Annual surveys on the vessel shall include reviewing records and history of rig maintenance measures against the specifications provided by the maintenance manual.**

### **4.5.3 Rigging fittings**

The strength of all blocks, shackles, rigging screws, cleats and associated fittings and attachment points should exceed the breaking strain of the associated running or standing rigging.

**4.5.4 Sails**

4.5.4.1 Adequate means of reefing or shortening sail should be provided.

4.5.4.2 Sailing vessels operating as Short Range Yachts need not carry storm canvas.

4.5.4.3 All other vessels should either be provided with separate storm sails or have specific sails designated and constructed to act as storm canvas.



Objective:- This section is intended to outline standards to be achieved for weathertight integrity. As far as is practicable, the standards of the 1966 ICLL are to be adhered to. However, due consideration may be given to arrangements that provide an equivalent level of safety in respect of the risks of down flooding and green sea loading.

### **Virtual Freeboard Deck**

For the purposes of this section only, where actual freeboard to the weather deck exceeds that required by ICLL 66 by at least one standard superstructure height, openings on that deck, abaft of the forward quarter, may be assumed to be in position 2. This is to be taken, unless otherwise stated, as defined in ICLL 66.

For vessels up to 75m load line length, a standard superstructure height is to be taken as 1.8m. For vessels over 125m load line length, this is to be taken as 2.3m. Superstructure heights for vessels of intermediate lengths should be obtained by interpolation.

## **5.1 Hatchways and Skylight Hatches**

### **5.1.1 General requirements**

5.1.1.1 All openings leading to spaces below the weather deck not capable of being closed weathertight, must be enclosed within either an enclosed superstructure or a weathertight deckhouse of adequate strength meeting with the requirements of the Load Line Assigning Authority.

5.1.1.2 All exposed hatchways which give access from position 1 and position 2 are to be of substantial weathertight construction and provided with efficient means of closure. Weathertight hatch covers should be permanently attached to the vessel and provided with adequate arrangements for securing the hatch closed.

5.1.1.3 Hatches which are designated for escape purposes should be provided with covers which are to be openable from either side and in the direction of escape they are to be openable without a key. All handles on the inside are to be non removable. An escape hatch should be readily identified and easy and safe to use, having due regard to its position.

### **5.1.2 Hatchways which are open at sea**

In general, hatches should be kept closed at sea. However, hatchways which may be kept open for access at sea are to be as small as practicable (a maximum of 1 square metre in clear area), and fitted with coamings of at least 300mm in height in positions 1 and 2 Hatchways should be as near to the centreline as practicable, especially on sailing vessels. Covers of hatchways are to be permanently attached to the hatch coamings and, where hinged, the hinges are to be located on the forward side.

## 5.2 Doorways and Companionways

### 5.2.1 Doorways located above the weather deck

5.2.1.1 External doors in deckhouses and superstructures that give access to spaces below the **weather deck are to be** weathertight and door openings should have coaming heights of at least:

Location	Unrestricted Yachts	Short Range Yachts
A	600mm	300mm
B	300mm	150mm
C	150mm	75mm

Location A The door is in the forward quarter length of the vessel and is used when the vessel is at sea.

Location B The door is in an exposed forward facing location aft of the forward quarter length.

Location C The door is in a protected location aft of the forward quarter length, or an unprotected door on the first tier deck above the weather deck.

5.2.1.2 Weathertight doors should be arranged to open outwards and when located in a houseside, be hinged at the forward edge. Alternative closing arrangements will be considered providing it can be demonstrated that the efficiency of the closing arrangements and their ability to prevent the ingress of water will not impair the safety of the vessel.

5.2.1.3 An access door leading directly to the engine room from the weather deck should be fitted with a coaming of height of at least:

Location	Unrestricted Yachts	Short Range Yachts
Position 1	600mm	450mm
Position 2	380mm	200mm

5.2.1.4 Coaming height, construction and securing standards for weathertight doors which are provided for use only when the vessel is in port or at anchor in calm sheltered waters and are locked closed when the vessel is at sea, may be considered individually.

### 5.2.2 Companion hatch openings

5.2.2.1 Companionway hatch openings which give access to spaces below the weather deck should be fitted with a coaming, the top of which is at least 300mm above the deck, or 150mm in the case of Short Range Yachts.

5.2.2.2 Washboards may be used to close the vertical opening. When washboards are used, they should be so arranged and fitted that they will not be dislodged readily. Whilst stowed, provisions are to be made to ensure that they are retained in a secure location.

5.2.2.3 The maximum breadth of an opening in a companion hatch should not exceed 1 metre.

### **5.3 Skylights**

5.3.1 All skylights should be of efficient weathertight construction and should be located on or as near to the centreline of the vessel as practicable.

5.3.2 If they are of the opening type they should be provided with efficient means whereby they can be secured in the closed position.

5.3.3 Skylights which are designated for escape purposes should be openable from either side, and in the direction of escape they are to be openable without a key. All handles on the inside are to be non-removable. An escape skylight should be readily identified and easy and safe to use, having due regard to its position.

5.3.4 The skylight glazing material and its method of securing within the frame should meet an appropriate national or international standard. Recognised Classification Society rules for "ships" are considered to meet these requirements. Where a recognised Classification Society produces alternative rules for "pleasure vessels" or "yachts", these are considered appropriate for Short Range Yachts.

A minimum of one portable cover for each size of glazed opening should be provided which can be accessed rapidly and efficiently secured in the event of a breakage of the skylight.

### **5.4 Portlights**

5.4.1 Portlights should be of strength appropriate to location in the vessel and meet an appropriate national or international standard. Recognised Classification Society rules for "ships" are considered to meet these requirements. Where a recognised Classification Society produces alternative rules for "pleasure vessels" or "yachts", these are considered appropriate for Short Range Yachts. With regard to structural fire protection, the requirements for the construction of certain portlights should meet the requirements of Section 14A and 14B.

5.4.2 In general, all portlights fitted in locations protecting openings to spaces below the weather deck or fitted in the hull of the vessel should be provided with a permanently attached deadlight which is to be capable of securing the opening watertight in the event of a breakage of the portlight glazing. Proposals to fit portable deadlights will be subject to special consideration and approval by the Administration, having regard for the location of the portlights and the ready availability of deadlights. Consideration should be given to the provision of operational instructions to the Master as to when deadlights must be applied to portlights.

5.4.3 Portlights fitted in the hull of the vessel below the level of the freeboard deck should be either non-opening or of a non-readily openable type and be in accordance with a standard recognised by the Administration. The lower edge of the portlights should be at least 500mm or 2.5% of the breadth of the vessel, whichever is the greater, above the all-seasons load line assigned to the vessel. Portlights of the non-readily opening type must be secured closed when the vessel is in navigation and indication provided on the bridge that they are closed.

5.4.4 Portlights should not be fitted in the hull in the way of the machinery space.

### **5.5 Windows**

5.5.1 Windows should be of strength appropriate to their location in the vessel and meet the requirements of BSMA 25 or equivalent international standard. Recognised Classification Society rules for "ships" are considered to meet these requirements.

Where a recognised Classification Society produces alternative rules for "pleasure vessels" or "yachts", these are considered appropriate for Short Range Yachts. With regard to structural fire protection, the requirements for the construction of certain windows should meet the requirements of 14A and 14B.

5.5.2 For all vessels where the glazing material, glazing thickness, or fixing of the windows does not meet the requirements of a recognised standard, windows may be tested, to the satisfaction of the Administration, at a minimum of 4 times the required design pressure derived from an appropriate national or international standard. Additionally, as a minimum, calculated thicknesses should meet Classification Society requirements for pleasure vessels or yachts. For Short Range Yachts, test pressures may be reduced to 2.5 times the derived design pressure.

5.5.3 When using BSMA 25 or equivalent, the following minimum design heads may be assumed when determining design head pressure:

First tier unprotected fronts	4.5 + L/100metres
Second tier unprotected fronts	3.5 metres
Elsewhere	1.5 metres

5.5.4 In general, windows fitted in superstructures or weathertight deckhouses are to be substantially framed and efficiently secured to the structure. The glass is to be of the toughened safety glass type.

5.5.5 Where chemically toughened safety glass is used, windows are to be of the laminated type, the minimum depth of chemical toughening to be 30 microns on exposed faces. Regular inspections of the windows, with particular reference to the surface condition, should form part of the operational procedures and annual survey by a Classification Society.

5.5.6 Windows should not be fitted in the main hull below the level of the freeboard deck. Proposals to fit large portlights in the main hull below the level of the freeboard deck will be subject to special consideration and approval by the Administration, having regard for their location and strength and their supporting structure and, the availability of strong protective covers for them. One item of the special consideration should be operational instructions to the Master as to when the strong protective covers must be fitted. Note: portlights of over 0.16m<sup>2</sup> may be referred to as windows in classification rules.

5.5.7 For all vessels, other than Short Range Yachts, storm shutters (preventative devices with fittings) are required for all windows in the front and sides of first tier and front windows of the second tier of superstructures or weathertight deckhouses above the freeboard deck.

5.5.7.1 Where windows are of laminated construction and their equivalent toughened safety glass thickness exceeds the requirements of the applied standard specified in 5.5.1 by a minimum of 30%, storm shutters need not be carried, but a blanking plate(s) is to be provided (a plate without fittings to fill damage holes) so that any window opening may be sealed in the event of glass failure. For windows subject to test in accordance with 5.5.2 only blanking plates are required.

When storm shutters are interchangeable port and starboard, a minimum of 50% of each size should be provided.

- 5.5.8 Side and front windows to the navigating position should not be constructed of polarised or tinted glass. (See Section 18.2.3)

## 5.6 Ventilators and Exhausts

- 5.6.1 Adequate ventilation is to be provided throughout the vessel. The accommodation is to be protected from the entry of gas and/or vapour fumes from machinery, exhaust and fuel systems, where exhaust systems pass through accommodation they should be fitted in a gas tight trunk fitted with a carbon monoxide detector.

- 5.6.2 Ventilators are to be of efficient construction and provided with permanently attached means of weathertight closure. Generally, ventilators serving any space below the freeboard deck or an enclosed superstructure should have a coaming of minimum height of:

Location	Unrestricted Yachts	Short Range Yachts
Forward quarter length	900mm	450mm
Elsewhere	760mm	380mm

- 5.6.3 Ventilators should be kept as far inboard as practicable and the height above the deck of the ventilator opening should be sufficient to prevent the ingress of water when the vessel heels.

- 5.6.4 The ventilation of spaces such as the machinery space, which must remain open, requires special attention with regard to the location and height of the ventilation openings above the deck, taking into account the effect of down flooding angle on stability standard. (See section 11.)

The means of closure of ventilators serving the machinery space should be selected with regard to the fire protection and extinguishing arrangements provided in the machinery space.

- 5.6.5 Engine exhaust outlets which penetrate the hull below the freeboard deck should be provided with means to prevent back flooding into the hull through a damaged exhaust system. For vessels operating on unrestricted service a positive means of closure should be provided. The system should be of equivalent construction to the hull on the outboard side of the closure. For Short Range Yachts, where the fitting of a positive closure is not practicable, the exhaust should be looped up above the waterline on the outboard side of the system, to a minimum height of 1000mm, and be of equivalent construction to the hull.

## 5.7 Air Pipes

- 5.7.1 Air pipes serving fuel and other tanks should be of efficient construction and provided with permanently attached means of weathertight closure. Means of closure may be omitted if it can be shown that the open end of an air pipe is afforded adequate protection by other structure(s) which will prevent the ingress of water.

- 5.7.2 Where located on the weather deck, air pipes should be kept as far inboard as practicable and be fitted with a coaming of sufficient height to prevent inadvertent flooding. Generally, air pipes to tanks should have a minimum coaming height of:

Location	Unrestricted Yachts	Short Range Yachts
On weather deck	760mm	380mm
Elsewhere	450mm	225mm

5.7.3 Air pipes to fuel tanks should terminate at a height of not less than 760mm above either, the top of the filler pipe for a gravity filling tank or, the top of the overflow tank for a pressure filling tank.

## 5.8 Scuppers, Sea Inlets and Discharges and Other Hull Penetrations

5.8.1 The standards of ICLL should be applied to every discharge led through the shell of the vessel as far as it is reasonable and practicable to do so, and in any case, all sea inlet and overboard discharges should be provided with efficient shut-off valves arranged in positions where they are readily accessible at all times.

5.8.2 Underwater lights fitted in the hull should be type approved. Installation should be subject to survey.

## 5.9 Materials for Valves and Associated Piping

5.9.1 Valves which are fitted below the waterline should be of steel, bronze or other material having a similar resistance to impact, fire and corrosion. Non metallic valves will not normally be considered equivalent.

5.9.2 The associated piping should, in areas as indicated above, be of steel, bronze, copper or other equivalent material. Non metallic piping will not normally be considered equivalent.

5.9.3 Where the use of plastic piping is proposed, it will be considered and full details of the type of piping, its intended location, and use, should be submitted for approval; with regard to watertight integrity, any plastic piping should be above the waterline. Due regard should be paid to the IMO Fire Test Procedures Code, and 14A.2.3.4 or 14B.2.11.6.

5.9.4 The use of flexible piping in any location should be kept to a minimum compatible with the essential reason for its use. Flexible piping and the means of joining it to its associated hard piping system should be approved as fit for the purpose.

## 5.10 General Equivalence

Where vessels cannot fully comply with the requirements of this section, equivalent arrangements may be considered by the Administration. Such proposals should take into account the following, although this should not be considered as an exhaustive list:

- Openings to be kept closed at sea
- Enhanced Bilge Pumping capacity and additional bilge alarms
- Compliance with damage stability if not already a requirement (see Section 11)
- Provision of dorade boxes or baffle systems to prevent direct ingress of water
- Alternative ventilation for use in bad weather
- Consideration of downflooding angle and reduced risk of green sea loads, i.e. protected position
- Enhanced survey inspection regime
- Operational Limitations

## 6

### WATER FREEING ARRANGEMENTS

Objective:- This section provides for consideration of the risks of green water being shipped aboard and the resulting consequences with respect to the vessels stability and safety of personnel on deck.

- 6.1 The standards for water freeing arrangements should comply with ICLL as far as it is reasonable and practicable to do so.

In any case the intention should be to achieve a standard of safety which is at least equivalent to the standard of ICLL.

Additionally, where a well is created on each side of the vessel between a superstructure or deckhouse, and the bulwark in way of that superstructure or deck house, the following formula may be used to determine the required freeing port areas on each side of the vessel for the well concerned:

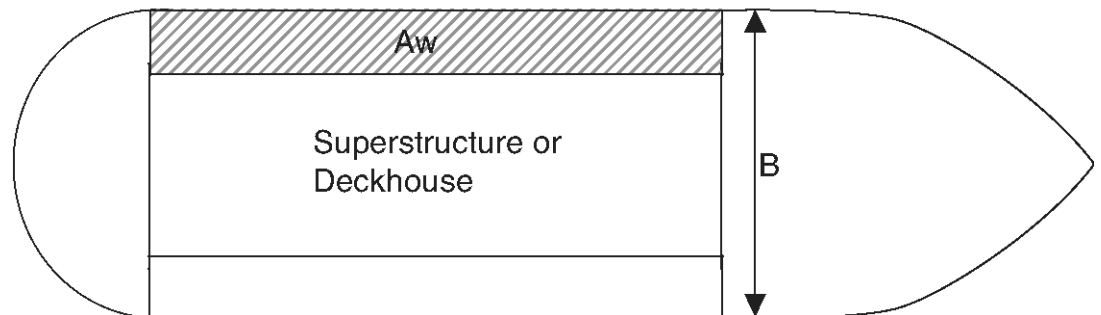

$$FP_{REQ} = 0.28 \times A_w / B$$

Where;

$FP_{REQ}$  = Freeing port area required

$A_w$  = Area of well in way of superstructure or deckhouse

$B$  = Full beam at deck,

On sailing vessels, where the solid bulwark height does not exceed 150mm, specific freeing ports, as defined above, are not required.

- 6.2 In individual cases, when the Administration considers that the requirements of ICLL cannot be met, the Administration may consider and approve alternative arrangements to achieve adequate safety standards. Freeing arrangements may take account of a reduced permeability and volume of the well, when compared to a full size well.

For Short Range Yachts it is considered that the requirement for freeing port area for a forward or after well may be reduced by a form factor equal to the ratio of (actual area well) divided by (length of well x breadth of well). Dimensions should be taken at half height of the bulwark. This may be reduced by 50% providing it can be shown that the intact stability of the yacht remains acceptable if the well is flooded to any level up to the bulwark height and that area provided will allow the well to drain in less than 3 minutes.

In considering an individual case, the Administration will take into account the vessels past performance in service and the declared area(s) of operation and any other conditions which restrict the use of the vessel at sea which will be recorded on the load line certificate issued to the vessel. (See section 4.1.3.)

### **6.3 Recesses**

6.3.1 Any recess in the weather deck should be of weathertight construction and should be self draining under all normal conditions of heel and trim of the vessel.

A swimming pool or spa bath, open to the elements, should be treated as a recess.

6.3.2 The means of drainage provided should be capable of efficient operation when the vessel is heeled to an angle of 10° in the case of a motor vessel (see 10A.2), and 30° in the case of a sailing vessel.

The drainage arrangements should have the capability of draining the recess (when fully charged with water) within 3 minutes when the vessel is upright and at the load line draught. Means should be provided to prevent the backflow of sea water into the recess.

6.3.3 When it is not practical to provide drainage which meets the requirements of 6.3.2, alternative safety measures may be proposed for approval by the Administration. Where the above requirements for quick drainage cannot be met, the effect on intact and damage stability should be considered taking into account the mass of water and its free surface effect.

## 7A

### MACHINERY - VESSELS OF LESS THAN 500GT

Objective:- This section outlines the minimum requirements for machinery, which are to be in accordance with the requirements of one of the Classification Societies defined in the National Annex and should cover the minimum aspects defined below, even if the machinery is not considered the primary means of propulsion. Existing Vessels which are not already Classed should be taken into Class, however alternative arrangements for Short Range operation may be agreed by the Administration.

#### 7A.1 General Requirements

7A.1.1 The machinery and its installation should, in general, meet with the requirements of one of the Classification Societies named in the National Annex. The Class Survey or Notation should include, as a minimum, propulsion and electrical generation machinery and shafting. For existing and new vessels which operate with periodically unattended machinery spaces, the machinery and its installation should meet the standards of SOLAS Chapter II-1/Part E - "Additional requirements for periodically unattended machinery spaces, so far as is reasonable and practicable to do so".

Plastic piping may be accepted where the piping and the arrangements for its use meet the requirements of the IMO Fire Test Procedures Code.

7A.1.2 The requirements for main propulsion are based upon the installation of diesel powered units. When other types of main propulsion are proposed, the arrangements and installation should be specially considered. Where gas turbines are to be fitted, attention should be paid to the guidance contained within the IMO High Speed Craft Code, and installation is to be to the satisfaction of the Administration.

7A.1.3 Notwithstanding the requirements of paragraph 7A.1.1, in a fuel supply system to an engine unit, where a flexible section of piping is provided, connections should be of a screw type or equivalent approved type. Flexible pipes should be fire resistant/metal reinforced. Materials and fittings should be of a suitable recognised national or international standard.

#### 7A.2 Installation

7A.2.1 Notwithstanding the requirements referred to in 7A.1, the machinery, fuel tanks and associated piping systems and fittings should be of a design and construction adequate for the service for which they are intended, and should be so installed and protected as to reduce to a minimum any danger to persons during normal movement about the vessel, with due regard being made to moving parts, hot surfaces, and other hazards.

7A.2.2 Means should be provided to isolate any source of fuel which may feed a fire in an engine space. A fuel shut-off valve(s) should be provided which is capable of being closed from a position outside the engine space. The valve(s) should be fitted as close as possible to the fuel tank(s).

7A.2.3 All external high-pressure fuel delivery lines between the high pressure fuel pumps and fuel nozzles should be protected with a jacketed tubing system capable of containing fuel resulting from a high-pressure line failure. The jacketed tubing system should include means for collection of leakage and arrangements should be provided for an alarm to be given in the event of a fuel line failure.

7A.2.4 When a glass fuel level gauge is fitted it should be of the "flat glass" type with self closing valves between the gauge and the tank.

## 7B MACHINERY - VESSELS OF 500GT AND OVER

Objective:- This section outlines the minimum requirements for machinery, which are to be in accordance with the requirements of one of the Classification Societies defined in the National Annex. The Class Notation should cover the minimum aspects defined within this chapter even if the machinery is not considered the primary means of propulsion.

- 7B.1 For existing and new vessels the machinery and its installation should meet the requirements of one of the Classification Societies and of SOLAS **Chapters** II-1/Part C Machinery installations and II-1/Part E - Additional requirements for periodically unattended machinery spaces, so far as is reasonable and practicable to do so.
- 7B.2 In any case the intention should be to achieve a standard of safety which is at least equivalent to the standard of SOLAS. Equivalence may be achieved by incorporating increased requirements to balance deficiencies and thereby achieve the required overall standard.
- 7B.3 Where gas turbines are to be fitted, attention should be paid to the guidance contained within the IMO High-speed Craft Code, and installation is to be to the satisfaction of the Administration.

## 8A

## ELECTRICAL INSTALLATIONS - VESSELS OF LESS THAN 500GT

Objective:- This section outlines the minimum requirements for electrical installations, which are to be in accordance with the requirements of one of the Classification Societies defined in the National Annex, and should cover the minimum aspects defined below. For sailing vessels, this should also cover the elements necessary to ensure safety of the vessel including control of the sails, where appropriate. Existing Vessels which are not already Classed should be taken into Class, however alternative arrangements for Short Range operation may be agreed by the Administration.

### 8A.1 Installation

8A.1.1 Particular attention should be paid to the provision of overload and short circuit protection of all circuits, except engine starting circuits supplied from batteries.

8A.1.2 Electrical devices working in potentially hazardous areas, into which petroleum vapour or other hydrocarbon gas may leak, should be of a type certified safe for the hazard.

8A.1.3 Cables and wiring serving essential or emergency power, lighting, internal communications or signals shall be routed clear of galleys, laundries, machinery spaces of Category A and their casings, spaces for storage of petrol, and other high risk fire areas.

### 8A.2 Lighting

8A.2.1 Lighting circuits, including those for emergency lighting, should be distributed through the spaces so that a total blackout cannot occur due to failure of a single protective device

8A.2.2 An emergency source of lighting should be provided which should be independent of the general lighting system. This source should be sufficient for up to 3 hours duration and should include navigation light supplies. The lighting is to provide sufficient lighting for personnel to escape from the accommodation or working spaces to their muster station, and launch and board survival craft. Additionally, this light, supplemented by torches, should be sufficient to permit emergency repairs to machinery etc.

### 8A.3 Batteries

Batteries of a type suitable for marine use and not liable to leakage should be used. Areas in which batteries are stowed should be provided with adequate ventilation to prevent an accumulation of gas which is emitted from batteries of all types. Reference should also be made to Section 14.1.5.

### 8A.4 Emergency Power

Emergency power should be readily available to supply the required emergency lighting, radio installation and navigation aids for a minimum of 3 hours. As a minimum, the navigation aids to be supplied by emergency power to include GPS, echo sounder and AIS. The emergency power supply should be adequate to also supply any electrical emergency equipment fitted, such as fire pumps, bilge pumps, watertight doors, and rescue boat davit.

The emergency source of power should be independent of the main power supply, external to the engine room, and with separate distribution.

**8B****ELECTRICAL INSTALLATIONS - VESSELS OF 500GT AND OVER**

Objective:- This section outlines the minimum requirements for electrical, installations which are to be in accordance with the requirements of one of the Classification Societies defined in the National Annex, and should cover the minimum aspects defined below. For sailing vessels, this should also cover the elements necessary to ensure safety of the vessel including control of the sails. where appropriate.

- 8B.1 The electrical equipment and its installation should meet the standards of SOLAS Chapter II-1/Part D - Electrical installations and II-1/Part E - Additional requirements for periodically unattended machinery spaces, where appropriate, so far as it is reasonable and practicable to do so.
- 8B.2 The emergency generator, if fitted, should be located above the uppermost continuous deck but may be located below this deck provided it is protected from the effects of fire and flooding. In all cases, the emergency generator should be separated from main generators and main switchboard by a division capable of ensuring its continued operation. The emergency generator should be self contained (independent of a sea water suction) and readily accessible from the open deck.
- 8B.3 Cables and wiring serving essential or emergency power, lighting, internal communications or signals shall be routed clear of galleys, laundries, machinery places of Category A and their casings, spaces for storage of petrol, and other high risk fire areas.

## 9A

### STEERING GEAR - VESSELS OF LESS THAN 500GT

Objective:- This section outlines the minimum requirements for steering gear, which are to be in accordance with the requirements of a recognised Classification Society. The Class Notation or Survey should cover the minimum aspects defined within this chapter. Due regard is to be paid to the requirements for emergency steering.

#### 9A.1

##### **General Requirements**

The steering gear and its installation should, in general, meet with the requirements of one of the Classification Societies named in the National Annex.

In the event that the above requirements cannot be met on an existing vessel, the Administration may be requested to consider and approve alternative arrangements to achieve adequate safety standards.

#### 9A.2

Vessels should be provided with means for directional control of adequate strength and suitable design to enable the heading and direction of travel to be effectively controlled at all operating speeds. When appropriate to the safe steering of the vessel, the steering gear should be power operated in accordance with the requirements of the Administration.

#### 9A.3

When the steering gear is fitted with remote control, arrangements should be made for emergency steering in the event of a failure of such control.

**9B****STEERING GEAR - VESSELS OF 500GT AND OVER**

Objective:- This section outlines the minimum requirements for steering gear, which are to be in accordance with the requirements a recognised Classification Society. The Class Notation should cover the minimum aspects defined within this chapter. Due regard is to be paid to the requirements for emergency steering.

9B.1

For existing and new vessels, the steering gear and its installation should meet the standards of SOLAS **Chapter** II-1/Part C - Machinery installations, so far as it is reasonable and practicable to do so.

9B.2

In any case, the intention should be to achieve a standard of safety which is at least equivalent to the standard of SOLAS. Equivalence may be achieved by incorporating increased requirements to balance deficiencies and thereby achieve the required overall standard.

## 10A

### BILGE PUMPING - VESSELS OF LESS THAN 500GT

Objective:- This section outlines the minimum requirements for bilge pumping, which are to be in accordance with the requirements of a recognised Classification Society. The Class Notation should cover the minimum aspects defined within this chapter. The principle objective of this section is that in the event of one compartment being flooded, which may or not be the engine room, there is an ability to control any leakage to adjacent compartments.

#### 10A.1

##### General Requirements

The bilge pumping equipment and its installation should, in general, meet with the requirements of a recognised Classification Society. Either the vessel should be in class or a statement of compliance issued by one of the Societies should be provided to the Administration

In the event that the above requirements cannot be met on an existing vessel, the Administration may be requested to consider alternative arrangements to achieve adequate safety standards.

#### 10A.2

All vessels should be provided with at least two fixed and independently powered **bilge** pumps, with suction pipes so arranged that any compartment can be effectively drained when the vessel is heeled to an angle of 10°. For Short Range Yachts, the second pump and suction pipes may be portable.

#### 10A.3

The location of pumps **required by 10A.2**, their individual power supplies and controls, including those for bilge valves, should be such that in the event of any one compartment being flooded **the bilge system is capable of removing water which may leak into adjacent compartments.**

#### 10A.4

Each bilge pump suction line should be fitted with an efficient strum box.

#### 10A.5

In the case of a vessel where the propulsion machinery space may be unmanned at any time, a bilge level alarm should be fitted. The alarm should provide an audible and visual warning in the Master's cabin and in the wheelhouse. The audible and visual alarm may be accepted elsewhere if it is considered that such a location may be more appropriate.

#### 10A.6

Pumping and piping arrangements for bilges into which fuel or other oils of similar or higher fire risk could collect, under either normal or fault conditions, should be kept clear of accommodation spaces and separate from accommodation bilge systems. Bilge level alarms meeting the requirements of 10A.5 should be fitted to all such bilges.

## 10B

### BILGE PUMPING - VESSELS OF 500GT AND OVER

Objective:- This section outlines the minimum requirements for bilge pumping, which are to be in accordance with the requirements of one of the Classification Societies defined in section 3. The Class Notation should cover the minimum aspects defined within this chapter. The principle objective of this section is that in the event of one compartment being flooded, which may or not be the engine room, there is an ability to control any leakage to adjacent compartments.

- 10B.1** For all vessels, the bilge pumping and its installation should as a minimum meet the cargo vessel standards of SOLAS Chapter II-1/Part B - Subdivision and stability Regulation 21.
- 10B.2** In any case, the intention should be to achieve a standard of safety which is at least equivalent to the standard of SOLAS. Equivalence may be achieved by incorporating increased requirements to balance deficiencies and thereby achieve the required overall standard.
- 10B.3** A minimum of two bilge pumps should be provided. The capacity of the pumps and the size of the bilge main and branches should meet the capacity requirements for passenger ships contained in SOLAS.
- 10B.4** In addition the minimum requirements for vessels of less than 500GT contained at section 10A, should also be met.

Objective:- This section outlines the minimum requirements for intact and damage stability. For vessels less than 85m Load Line length, a minor damage methodology is adopted in which damage is assumed not to occur on any bulkhead, deck, or other watertight boundary.

## 11.1 General

11.1.1 This section deals with the standards for both intact and damage stability.

11.1.2 An intact stability standard proposed for assessment of a vessel type not covered by the standards defined in the Code should be submitted to the Administration for approval at the earliest opportunity.

11.1.3 If used, permanent ballast should be located in accordance with a plan approved by the Administration and in a manner that prevents shifting of position. Permanent ballast should not be removed from the ship or relocated within the ship without the approval of the Administration. Permanent ballast particulars should be noted in the ship's stability booklet. Attention should be paid to local or global hull strength requirements from the point of view of the fitting of additional ballast.

## 11.2 Intact Stability Standards

### 11.2.1 Motor vessels

#### 11.2.1.1 Monohull Vessels

The curves of statical stability for seagoing conditions should meet the following criteria:

- .1 the area under the righting lever curve (GZ curve) should not be less than 0.055 metre-radians up to 30° angle of heel and not less than 0.09 metre-radians up to 40° angle of heel, or the angle of downflooding, if this angle is less;
- .2 the area under the GZ curve between the angles of heel of 30° and 40° or between 30° and the angle of downflooding if this is less than 40°, should not be less than 0.03 metre-radians;
- .3 the righting lever (GZ) should be at least 0.20 metres at an angle of heel equal to or greater than 30°;
- .4 the maximum GZ should occur at an angle of heel of preferably exceeding 30° but not less than 25°;
- .5 after correction for free surface effects, the initial metacentric height (GM) should not be less than 0.15 metres; and
- .6 in the event that the vessels intact stability standard fails to comply with the criteria defined in .1 to .5 the Administration may be consulted for the purpose of specifying alternative but equivalent criteria.

### 11.2.1.2 Monohull Vessels operating as Short Range Yachts

Where Short Range Yachts are unable to meet the criteria above, the following criteria may be used:

- .1 the area under the righting lever curve (GZ curve) should not be less than 0.07 metre-radians up to 15° angle of heel, when maximum GZ occurs at 15°, and 0.055 metre-radians up to 30° angle of heel, when maximum GZ occurs at 30° or above. Where the maximum GZ occurs at angles of between 15° and 30°, the corresponding area under the GZ curve,  $A_{req}$  should be taken as follows:-  
$$A_{req} = 0.055 + 0.001(30^\circ - \theta_{max}) \text{ metre.radians}$$
where  $\theta_{max}$  is the angle of heel, in degrees, where the GZ curve reaches its maximum.
- .2 the area under the GZ curve between the angles of heel of 30° and 40° or between 30° and the angle of downflooding if this is less than 40°, should not be less than 0.03 metre-radians;
- .3 the righting lever (GZ) should be at least 0.20 metres at an angle of heel equal to or greater than 30°;
- .4 the maximum GZ should occur at an angle of heel not less than 15°;
- .5 after correction for free surface effects, the initial metacentric height (GM) should not be less than 0.15 metres.

### 11.2.1.3 Multi-hulls

The curves of statical stability for seagoing conditions should meet the following criteria:

- .1 the area under the righting lever curve (GZ curve) should not be less than 0.075 metre-radians up to an angle of 20° when the maximum righting lever (GZ) occurs at 20° and, not less than 0.055 metre-radians up to an angle of 30° when the maximum righting lever (GZ) occurs at 30° or above. When the maximum GZ occurs at angles between 20° and 30° the corresponding area under the GZ curve,  $A_{req}$  should be taken as follows:-  
$$A_{req} = 0.055 + 0.002(30^\circ - \theta_{max}) \text{ metre.radians};$$
where  $\theta_{max}$  is the angle of heel in degrees where the GZ curve reaches its maximum.
- .2 the area under the GZ curve between the angles of heel of 30° and 40°, or between 30° and the angle of downflooding if this is less than 40°, should not be less than 0.03 metre-radians;
- .3 the righting lever (GZ) should be at least 0.20 metres at an angle of heel where it reaches its maximum;
- .4 the maximum GZ should occur at an angle of heel not less than 20°;

.5 after correction for free surface effects, the initial metacentric height (GM) should not be less than 0.15 metres; and

.6 if the maximum righting lever (GZ) occurs at an angle of less than 20° approval of the stability should be considered by the Administration as a special case.

11.2.1.4 For the purpose of assessing whether the stability criteria are met, GZ curves should be produced for the loading conditions applicable to the operation of the vessel.

#### 11.2.1.5 **Superstructures**

11.2.1.5.1 The buoyancy of enclosed superstructures complying with regulation 3(10)(b) of the ICLL may be taken into account when producing GZ curves.

11.2.1.5.2 Superstructures, the doors of which do not comply with the requirements of regulation 12 of ICLL, should not be taken into account.

#### 11.2.1.6 **High Speed Vessels**

In addition to the criteria above designers and builders should address the following hazards which are known to affect vessels operating in planing modes or those achieving relatively high speeds:

- .1 directional instability, often coupled to roll and pitch instabilities;
- .2 bow diving of planing vessels due to dynamic loss of longitudinal stability in calm seas;
- .3 reduction in transverse stability with increasing speed in monohulls;
- .4 porpoising of planing monohulls being coupled with pitch and heave oscillations;
- .5 generation of capsizing moments due to immersion of chines in planing monohulls (chine tripping).

#### 11.2.2 **Sailing vessels**

##### 11.2.2.1 **Monohulls**

- .1 Curves of statical stability (GZ curves) for at least the Loaded Departure with 100% consumables and the Loaded Arrival with 10% consumables should be produced.
- .2 The GZ curves required by .1 should have a positive range of not less than 90°. For vessels of more than 45m, a range of less than 90° may be considered but may be subject to agreed operational criteria..
- .3 In addition to the requirements of .2, the angle of steady heel should be greater than 15 degrees (see figure). The angle of steady heel is obtained from the intersection of a "derived wind heeling lever" curve with the GZ curve required by .1.

In the figure:-

'dwhl' = the "derived wind heeling lever" at any angle  $\theta^\circ$

$$= 0.5 \times WLO \times \cos^{1.2}\theta$$

where  $WLO = \frac{GZ_f}{\cos^{1.2}\theta_f}$

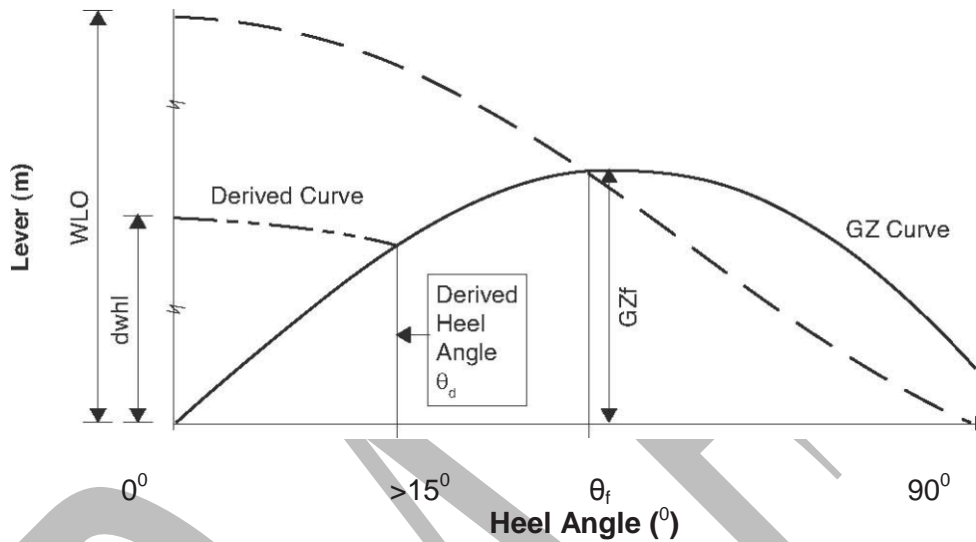

Noting that:

$O =$  is the magnitude of the actual wind heeling lever at  $0^\circ$  which would cause the vessel to heel to the 'down flooding angle'  $\theta_f$  or  $60^\circ$  whichever is least.

$GZ_f =$  is the lever of the vessel's GZ at the down flooding angle ( $\theta_f$ ) or  $60^\circ$  whichever is least.

$\theta_d =$  is the angle at which the 'derived wind heeling' curve intersects the GZ curve. (If  $\theta_d$  is less than  $15^\circ$  the vessel will be considered as having insufficient stability for the purpose of the Code).

$\theta_f =$  the 'down-flooding angle' is the angle of heel causing immersion of the lower edge of openings having an aggregate area, in square metres, greater than:-

$$\frac{\Delta}{1500} = \text{where } \Delta = \text{vessels displacement in tonnes}$$

All regularly used openings for access and for ventilation should be considered when determining the downflooding angle. No opening regardless of size which may lead to progressive flooding should be immersed at an angle of heel of less than  $40^\circ$ . Air pipes to tanks can, however, be disregarded.

If, as a result of immersion of openings in a superstructure, a vessel cannot meet the required standard, those superstructure openings may be ignored and the openings in the weather deck used instead to determine  $\theta_f$ . In such cases the GZ curve should be derived without the benefit of the buoyancy of the superstructure.

It might be noted that provided the vessel complies with the requirements of 11.2.2.1.1, 11.2.2.1.2 and 11.2.2.1.3 and is sailed with an angle of heel which is no greater than the 'derived angle of heel', it should be capable of withstanding a wind gust equal to 1.4 times the actual wind velocity (i.e. twice the actual wind pressure) without immersing the 'down-flooding openings', or heeling to an angle greater than 60°.

#### 11.2.2.2 Multi-hulls

.1 Curves of statical stability in both roll and pitch shall be prepared for at least the Loaded Arrival with 10% consumables. The VCG shall be obtained by one of the three methods listed below:

- .1 inclining of complete craft in air on load cells, the VCG being calculated from the moments generated by the measured forces; or
- .2 separate determination of weights of hull and rig (comprising masts and all running and standing rigging), and subsequent calculation assuming that the hull VCG is 75% of the hull depth above the bottom of the canoe body, and that the VCG of the rig is at half the length of the mast (or a weighted mean of the lengths of more than one mast); or
- .3 a detailed calculation of the weight and CG position of all components of the vessel, plus a 15% margin of the resulting VCG height above the underside of canoe body.

.2 If naval architecture software is used to obtain a curve of pitch restoring moments, then the trim angle must be found for a series of longitudinal centre of gravity (LCG) positions forward of that necessary for the design waterline. The curve can then be derived as follows:

$$GZ \text{ in pitch} = CG' \times \cos(\text{trim angle})$$

$$\text{trim angle} = \tan^{-1} \left( \frac{T_{FP} - T_{AP}}{L_{BP}} \right)$$

- where: CG' = shift of LCG forward of that required for design trim, measured parallel to baseline  
 $T_{FP}$  = draught at forward perpendicular  
 $T_{AP}$  = draught at aft perpendicular  
 $L_{BP}$  = length between perpendiculars

Approximations to maximum roll or pitch moments are not acceptable.

- .3 Data shall be provided to the user showing the maximum advised mean apparent wind speed appropriate to each combination of sails, such wind speeds being calculated as the lesser of the following:

$$v_w = 1.5 \sqrt{\frac{L_R M}{A'_S h c \phi_R + sA_D b}}$$

or

$$v_w = 1.5 \sqrt{\frac{L_P M}{A'_S h c \phi_P + sA_D b}}$$

where

$v_w$  = maximum advised apparent wind speed (knots)

$LM_R$  = maximum restoring moment in roll (N.m)

$LM_P$  = limiting restoring moment in pitch (N.m), defined as the pitch restoring moment at the least angle of the following:

- a) angle of maximum pitch restoring moment, or
- b) angle at which foredeck is immersed
- c)  $10^\circ$  from design trim

$A'_S$  = area of sails set including mast and boom (square metres)

$h$  = height of combined centre of effort of sails and spars above the waterline

$\phi_R$  = heel angle at maximum roll righting moment (in conjunction with  $LM_R$ )

$\phi_P$  = limiting pitch angle used when calculating  $LM_P$  (in conjunction with  $LM_P$ )

$A_D$  = plan area of the hulls and deck (square metres)

$b$  = distance from centroid of  $A_D$  to the centreline of the leeward hull

This data shall be accompanied by the note:

*In following winds, the tabulated safe wind speed for each sail combination should be reduced by the boat speed.*

- .4 If the maximum safe wind speed under full fore-and-aft sail is less than 27 knots, it shall be demonstrated by calculation using annex D of ISO 12217-2 (2002) that, when inverted and/or fully flooded, the volume of buoyancy, expressed in cubic metres (m<sup>3</sup>), in the hull, fittings and equipment is greater than:

$$1.2 \times (\text{fully loaded mass in tonnes})$$

thus ensuring that it is sufficient to support the mass of the fully loaded vessel by a margin. Allowance for trapped bubbles of air (apart from dedicated air tanks and watertight compartments) shall not be included.

- .5 The maximum safe wind speed with no sails set calculated in accordance with .3 above should exceed 36 knots. For Short Range Yachts this wind speed should exceed 32 knots.
- .6 Trimarans used for unrestricted operations should have sidehulls each having a total buoyant volume of at least 150% of the displacement volume in the fully loaded condition.
- .7 The stability information booklet shall include information and guidance on:
- .1 the stability hazards to which these craft are vulnerable, including the risk of capsize in roll and/or pitch;
  - .2 the importance of complying with the maximum advised apparent wind speed information supplied;
  - .3 the need to reduce the tabulated safe wind speeds by the vessel speed in following winds;
  - .4 the choice of sails to be set with respect to the prevailing wind strength, relative wind direction, and sea state;
  - .5 the precautions to be taken when altering course from a following to a beam wind.
- .8 In vessels required to demonstrate the ability to float after inversion (according to .3 above), an emergency escape hatch shall be fitted to each main inhabited watertight compartment such that it is above both upright and inverted waterlines.

### 11.3 Damage Stability

The following requirements are applicable to all vessels, other than those operating as Short Range Yachts. Whilst Short Range Yachts are not required to meet the damage stability criteria defined above, ultimate survivability after minor damage or flooding is recommended.

It should be noted that compliance with the damage stability criteria is not required for vessels that obtain full compliance with the ICLL conditions of assignment.

- 11.3.1 The watertight bulkheads of the vessel should be so arranged that minor hull damage that results in the free flooding of any one compartment, will cause the vessel to float at a waterline which, at any point, is not less than 75mm below the weather deck, freeboard deck, or bulkhead deck if not concurrent.
- 11.3.2 Minor damage should be assumed to occur anywhere in the length of the vessel, but not on a watertight bulkhead.

11.3.3

Standard permeabilities should be used in this assessment, as follows:

Space	Percentage Permeability
Stores	60
Stores but not a substantial quantity thereof	95
Accommodation	95
Machinery	85

11.3.4 In the

d  
a  
m  
a  
g

ed condition, considered in 11.3.1, the residual stability should be such that any angle of equilibrium does not exceed  $7^\circ$  from the upright, the resulting righting lever curve has a range to the downflooding angle of at least  $15^\circ$  beyond any angle of equilibrium, the maximum righting lever within that range is not less than 100mm and the area under the curve is not less than 0.015 metre radians.

GZ Lever (m)

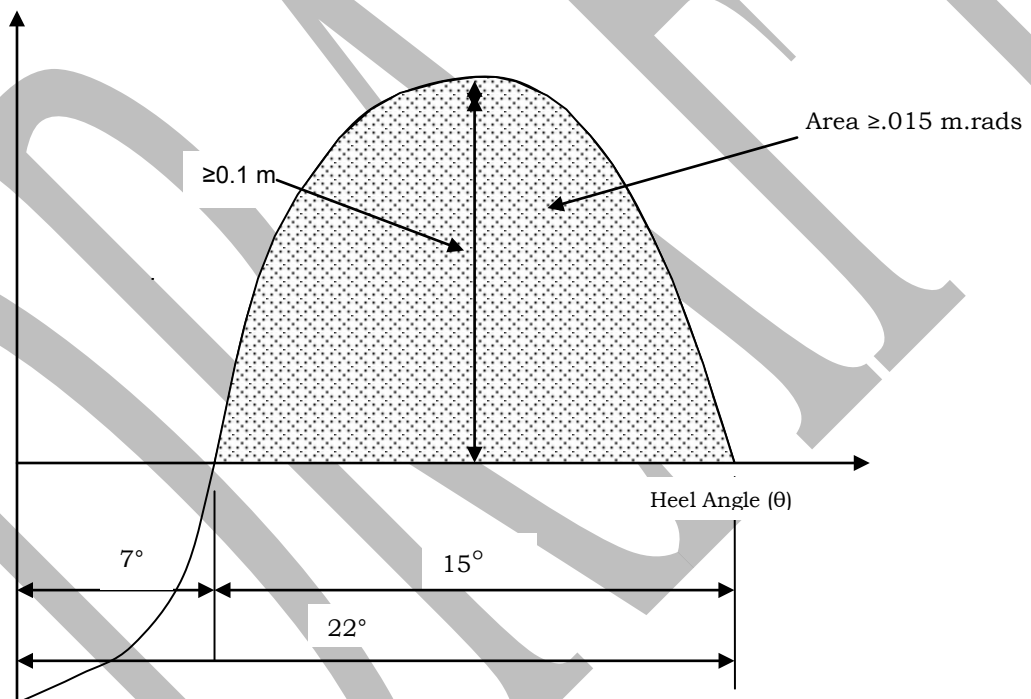

11.3.5

A vessel of 85 metres length and above should meet a SOLAS one-compartment standard of subdivision, calculated using the deterministic damage stability methodology.

#### 11.4 Elements of Stability

11.4.1

Unless otherwise specified, the lightship weight, vertical centre of gravity (KG) and longitudinal centre of gravity (LCG) of a vessel should be determined from the results of an inclining experiment.

11.4.2

An inclining experiment should be conducted in accordance with a detailed

standard which is approved by the Administration and, in the presence of an authorised surveyor.

SECRET

- 11.4.3 The report of the inclining experiment and the lightship particulars derived should be approved by the Administration prior to its use in stability calculations.

At the discretion of the owner(s)/managing agent(s) and prior to approval of the lightship particulars by the Administration, a margin for safety may be applied to the lightship weight and KG calculated after the inclining experiment. Such a margin should be clearly identified and recorded in the stability booklet.

A formal record should be kept in the stability booklet of alterations or modifications to the vessel for which the effects on lightship weight and vertical centres of gravity are offset against the margin.

- 11.4.4 When sister vessels are built at the same shipyard, the Administration may accept a lightweight check on subsequent vessels to corroborate the results of the inclining experiment conducted on the lead vessel of the class.

## 11.5 Stability Documents

- 11.5.1 A vessel should be provided with a stability information booklet for the Master, that is to be approved by the Administration.

- 11.5.2 The content, form and presentation of information contained in the stability information booklet should be based on the model booklet for the vessel type (motor or sailing) published by/for the Administration.

- 11.5.3 A vessel with previously approved stability information which undergoes a major refit or alterations should be subjected to a complete reassessment of stability and provided with newly approved stability information.

A major refit or major alteration is one which results in either a change in the lightship weight of 2% and above and/or the longitudinal centre of gravity of 1% and above (measured from the aft perpendicular) and/or the calculated vertical centre of gravity rises by 0.25% and above (measured from the keel).

Additionally, unless it can be clearly demonstrated that no major change has occurred, a lightweight check should be carried out at the renewal survey required by 28.4.1.

- 11.5.4 Sailing vessels should have, readily available, a copy of the 'Curves of Maximum Steady Heel Angle to Prevent Downflooding in Squalls', or in the case of a multihull, the values of maximum advised mean apparent wind speed, for the reference of the watchkeeper. This should be a direct copy taken from that contained in the approved stability booklet.

- 11.5.5 The overall sail area and spar weights and dimensions should be as documented in the vessel's stability information booklet. Any rigging modifications that increase the overall sail area, or the weight/dimensions of the rig aloft, must be accompanied by an approved updating of the stability information booklet.

- 11.5.6 For Short Range Yachts, where the damage stability has not been assessed, the following note should be added to the approved stability booklet;

"This vessel has not been assessed for damage stability, and therefore might not remain afloat in the event of damage or flooding."

Objective:- The purpose of this section is to ensure that all vessels are assigned a freeboard in accordance with ICLL 1966. This section also outlines the requirements for draught marks to enable trim to be readily calculated.

## 12.1 General

12.1.1 The freeboard for the vessel and its marking should be approved by the Assigning Authority for the assignment of freeboard and issue of the International Load Line Certificate (1966).

12.1.2 Vessels should comply with ICLL for the assignment of a freeboard mark which corresponds to the deepest loading condition included in the stability information booklet for the vessel.

12.1.3 The freeboard assigned should be compatible with the strength of hull structure, intact and damage stability requirements for the vessel, and should ensure that minimum bow height requirements are met.

12.1.4 The Assigning Authority should provide the owner(s)/managing agent(s) of the vessel with a copy of the particulars of the freeboard assigned and a copy of the record of particulars relating to the conditions of assignment.

## 12.2 Freeboard Mark and Loading

12.2.1 The freeboard mark applied should be positioned port and starboard at amidships on the load line length and may be an all-seasons mark. The mark should be a permanent disc and be of contrasting colour to the hull of the vessel in way of the mark.

12.2.2 The fresh water freeboard allowance should be obtained by deducting from the all-seasons freeboard assigned, the quantity

$$\frac{\Delta}{4T} \quad \text{millimetres}$$

where:-

$\Delta$  = displacement in salt water in tonnes at the all-seasons draught

T = tonnes per centimetres immersion at the all seasons load waterline

Alternatively the deduction may be taken as 1/48th of the all-seasons draught of the ship at amidships.

12.2.3 A vessel should not operate in any condition which will result in its appropriate freeboard marks being submerged when it is at rest and upright in calm water.

## 12.3 Datum Draught Marks

12.3.1 Datum draught marks should be provided at the bow and stern, port and starboard, and be adequate for assessing the condition and trim of the vessel. Such draught marks maybe single datum lines.

12.3.2 The marks should be permanent and easily read but need not be of contrasting colour to the hull. The marks need not indicate more than one draught at each position and should be above, but within 1000mm, of the deepest load waterline.

12.3.3 The draught to which marks relate should be indicated either above the mark on the hull and/or in the stability information booklet for the vessel. The position of the marks should be verified at initial placement by the Administration or the vessel's Assigning Authority.

DEEPEST

Objective:- The purpose of this section is to ensure that all vessels are equipped with the minimum essential LSA equipment appropriate to yacht operations. The basic provision is for the principles of SOLAS to be met, however, some sections have been identified where alternative standards can be accepted, where appropriate.

### 13.1 General Requirements

13.1.1 Life-Saving Appliances should be provided in accordance with Table 1 - Life-Saving Appliances.

13.1.2 All equipment fitted should be of a type which has been accepted by the Administration as complying with IMO Life-Saving Appliances Code and IMO Resolution MSC.81(70).

13.1.3 Additional life-saving equipment which is provided should meet the requirements of 13.1.2.

When personal safety equipment is provided for use in water sports activities, arrangements for its stowage should ensure that it will not be used mistakenly as lifesaving equipment in an emergency situation.

13.1.4 All life-saving equipment carried should be fitted with retro-reflective material in accordance with the recommendations of IMO Resolution A.658(16) as amended.

13.1.5 Liferaft embarkation arrangements should comply with the following:

.1 Where the distance between the embarkation deck and the top of the liferaft buoyancy tube exceeds 1 metre with the vessel in its lightest condition, an embarkation ladder is to be provided. A means for fastening is to be provided and ladders are to be readily available for use at all times.

.2 Where the distance between the embarkation deck and the top of the liferaft buoyancy tube exceeds 4.5 metres with the vessel in its lightest condition, davit launched liferafts and at least one launching appliance for launching are to be provided on each side of the vessel.

13.1.6 Falls for launching devices are to comply with IMO Life-Saving Appliances Code. When falls are of stainless steel, they should be renewed at intervals not exceeding the service life recommended by the manufacturer, or where no service life is stated be treated as galvanised steel falls. Falls of alternative materials may be considered by the Administration.

13.1.7 Every inflatable or rigid inflatable rescue boat, inflatable boat, inflatable liferaft and hydrostatic release unit should be serviced, at intervals not exceeding 12 months, at an approved service station. Hydrostatic release units which have been approved for a service life of 2 years and which should be replaced at the end of their life, need not be serviced after 1 year.

13.1.8 Maintenance of equipment should be carried out in accordance with the instructions for onboard maintenance.

- 13.1.9 The stowage and installation of all life-saving appliances is to be to the satisfaction of the Administration.
- 13.1.10 All life-saving appliances should be in working order and be ready for immediate use at the commencement of, and at all times during, the voyage.
- 13.1.11 For a vessel equipped with stabiliser fins or having other projections at the sides of the hull, special consideration should be given, and provisions made, as necessary to avoid possible interference with the safe evacuation of the vessel in an emergency.
- 13.1.12 Means should be provided to prevent overboard discharge of water into survival craft.

DRAFT

**Table 1 - LIFE-SAVING APPLIANCES**

<b>VESSEL SIZE</b>	Short Range Yacht	≥ 24m	≥ 500GT	≥ 85m
LIFEBOATS (see 13.2.1)	-	-	-	YES
LIFERAFTS (see 13.2.2)	YES	YES	YES	YES
MANOVBORD RECOVERY SYSTEM (see 13.2.3.3)	YES	-	-	-
RESCUE BOAT (see 13.2.3)	-	YES	YES	YES
LIFEJACKETS (see 13.2.7)	YES	YES	YES	YES
IMMERSION SUITS (see 13.2.8)	YES	YES	YES	YES/2/0
LIFEBUOYS (TOTAL)	4	4	8	8
LIFEBUOYS WITH LIGHT AND SMOKE (see 13.2.9.1)	2	2	2	2
LIFEBUOYS WITH LIGHT	-	-	2	2
LIFEBUOYS WITH BUOYANT (see 13.2.9.2) LIFELINE	2	2	2	2
SET OF LINE THROWING APPLIANCES (4 lines plus 4 charges)	1	1	1	1
ROCKET PARACHUTE FLARES	6	6	12	12
TWO-WAY RADIOTELEPHONE SETS	2	2	2	3
EPIRB (see 13.2.10)	1	1	1	1
SART (see 13.2.11)	1	1	2	2
GENERAL ALARM (see 13.2.12)	YES	YES	YES	YES
LIGHTING (see 13.2.13)	YES	YES	YES	YES
POSTERS AND SIGNS SHOWING SURVIVAL CRAFT AND EQUIPMENT OPERATING INSTRUCTIONS YES	YES	YES	YES	YES
TRAINING MANUAL	YES	YES	YES	YES
INSTRUCTIONS FOR ONBOARD MAINTENANCE	YES	YES	YES	YES
LIFESAVING SIGNALS AND (see 13.2.14) RESCUE POSTER - SOLAS No 1 IN WHEELHOUSE	YES	YES	YES	YES

## **13.2 Equipment Carriage Requirements**

### **13.2.1 Lifeboats (Required for vessels over 85m in length)**

- 13.2.1.1 When lifeboats are required to be carried their acceptance is conditional upon the provision of suitable stowage and launching arrangements.
- 13.2.1.2 When lifeboats are provided on each side of the vessel, the lifeboat(s) on each side should be of capacity to accommodate the total number of persons onboard.
- 13.2.1.3 Alternative arrangements to the carriage of lifeboats may be considered as indicated below:
- .1 substitution of lifeboats by liferafts where the vessel complies with a SOLAS 2 compartment subdivision standard; or
  - .2 substitution of lifeboats by a sufficient number of davit launched liferafts such that in the event of any one liferaft being lost or rendered unserviceable, sufficient aggregate capacity remains on either side of the vessel for all persons on board. Additionally one approved rescue boat should be provided on either side of the vessel.
- 13.2.1.4 A lifeboat will also be acceptable as a rescue boat provided it also meets the requirements of the IMO Life-Saving Appliances Code as a rescue boat.

### **13.2.2 Liferafts**

- 13.2.2.1 The liferafts carried are to be stowed in GRP containers and must contain the necessary "emergency pack". For Short Range Yachts, or vessels operating within 60 miles from a safehaven, liferafts provided may be equipped with a "SOLAS B PACK". For all other vessels, liferafts should be equipped with a "SOLAS A PACK".
- 13.2.2.2 Liferaft approval includes approval of their stowage, launching and float-free arrangements.
- 13.2.2.3 For vessels of less than 85m in length, or those complying with 13.2.1.3, a sufficient number of liferafts should be provided so that in the event of any one liferaft being lost or rendered unserviceable, sufficient aggregate capacity remains on either side of the vessel for all persons on board. This may be achieved by transferring liferafts from one side to the other. Where liferafts are transferable, this requirement may be met by the ability of the rafts to be transferred within 5 minutes, as below:-
- Liferafts of 6 - 15 persons capacity to be carried by 2 persons  
Liferafts of more than 15 persons capacity to be carried by 4 persons.
- 13.2.2.4 When lifeboats are provided in accordance with 13.2.1.2, sufficient liferafts are to be provided such that in the event of any one lifeboat being lost or rendered unserviceable, sufficient aggregate liferaft capacity remains on either side of the vessel for all persons onboard. Where liferafts are transferable, this requirement may be met by the ability of the rafts to be transferred within 5 minutes, as detailed in 13.2.2.3.
- 13.2.2.5 GRP containers containing liferafts should be stowed on the weather deck or in an open space and fitted with hydrostatic release units so that the liferafts will float free of the vessel and automatically inflate.

13.2.2.6 Liferrafts may form part of an approved Marine Evacuation System (MES). A sufficient number of systems should be provided, such that in the event of any one entire system being lost or rendered unserviceable, sufficient aggregate capacity remains on either side of the vessel for all persons on board.

13.2.2.7 For vessels operating with reduced personnel aboard, attention is drawn to the dangers associated with the use of large capacity liferafts with small numbers of persons embarked.

### **13.2.3 Rescue Boats and Recovery of Persons from the Sea**

13.2.3.1 Means should be provided for the recovery of a person from the sea to the vessel and it should be assumed that the person is unconscious or unable to assist in the rescue. This requirement is satisfied by the following sections as appropriate to the size of the vessel. If an overside boarding ladder or scrambling net is provided the ladder or net should extend from the weather deck to at least 600mm below the lowest operational waterline.

13.2.3.2 All rescue boats covered within this section are to be equipped to the requirements of the IMO Lifesaving Appliance Code Ch V/5.1.2. Additionally, rescue boats need not be capable of being launched from both sides, and means to lower the boat from within the boat is not required.

13.2.3.3 **Forward launching over the flair of the bow is not considered good practice, and design of new build yachts should allow for launching the rescue boat down a flat side of the hull, as far as practicable.**

### **13.2.4 Vessels of 500GT and over**

13.2.4.1 All vessels of 500GT and over should be provided with a rescue boat meeting SOLAS requirements in all respects, except for the colour where white will also be considered acceptable.

13.2.4.2 The launching appliances should comply and be approved in accordance with the IMO Lifesaving Appliance Code except that when a power operated crane is fitted, it should be capable of operation either by hand or by an emergency source of power in the event of a main power failure. The routing of the emergency source of power should be considered in respect of damaged waterlines and fire.

### **13.2.5 Vessels under 500GT**

13.2.5.1 Vessels under 500GT should be provided with a rescue boat either meeting the requirements of 13.2.3.1 or the following:

13.2.5.2 A boat which is not SOLAS approved but which is suitable for rescue purposes. The boat may be rigid, rigid inflatable, or inflatable, and should have a capacity for not less than 4 persons, one of which should be assumed to be lying down. Tubes of rigid inflatable or inflatable boats should have a minimum of 3 buoyancy compartments. The boat is to be capable of displaying a highly visible colour. **If the equipment as required by the LSA Code is stowed in a grab bag, it need not be permanently stowed in the boat.**

13.2.5.3 Launching appliances should be either of an approved type or comply with the following requirements:

13.2.5.4 The appliance should be able to launch the boat within 5 minutes. When a power operated device is fitted, it should be capable of operation either by hand or by an emergency source of power in the event of a main power failure. The routing of the emergency source of power should be considered in respect of damaged waterlines and fire.

13.2.5.5 The launching appliance and its attachments should be constructed to withstand a static proof load on test of not less than 2.2 times the maximum working load. Acceptable factors of safety are 6 for wires, hooks and sheaves, and 4.5 for the remainder of the launching appliance. The appliance and its attachments should also be tested dynamically to 1.1 times the working load. It should be noted that there is no requirement to recover the rescue boat provided that the casualty and the boat's crew can be recovered on board from the boat in the water.

The design of the falls and winch system should take account of the principles of IMO Lifesaving Appliances Code Ch VI/6.1.2

13.2.5.6 Where it is proposed to use the running rigging on sailing vessels, the above requirements should also be met.

### **13.2.6 Short Range Yachts**

13.2.6.1 Vessels operating as Short Range Yachts should either comply with requirements of 13.2.3.1 or 13.2.3.2, or the following:

13.2.6.2 The vessel should have sufficient mobility and manoeuvrability in a seaway to enable persons to be retrieved from the water. For assessing this ability it is not considered acceptable to retrieve persons over the stern of the vessel or adjacent to the propeller(s). The recovery location should be visible from the conning position at all times during the recovery, although this may be achieved by the use of remote controls where necessary.

13.2.6.3 The vessel should be provided with suitable equipment and/or arrangements to enable the person(s) to be recovered without further persons entering the water.

### **13.2.7 Lifejackets**

13.2.7.1 One adult SOLAS approved lifejacket should be provided for each person onboard plus spare adult lifejackets sufficient for at least 10% of the total number of persons onboard or two, whichever is the greater. Each lifejacket should be fitted with a light and whistle.

13.2.7.2 If the adult lifejackets provided are not designed to fit persons weighing up to 140 kg and with a chest girth of up to 1,750 mm, a sufficient number of suitable accessories as may be required to provide a lifejacket for each such person shall be available on board to allow them to be secured to such persons.

13.2.7.3 Included in the above number of lifejackets, there should be at least two SOLAS approved inflatable lifejackets for use of the crew of any rescue boat or inflatable boat carried onboard.

13.2.7.4 A number of lifejackets suitable for children to provide a lifejacket for each child shall be provided.

### **13.2.8 Immersion Suits**

- 13.2.8.1 One approved immersion suit should be provided for each person onboard. **These may be of the non-insulated type.**
- 13.2.8.2 Due consideration should be given to the provision of appropriate immersion / thermal protection for children carried on board.
- 13.2.8.3 **For cold water areas of operation, the insulated type should be carried. Reference to Resolution IMO MSC Circular 1046 should be made for assessment of thermal protection.**

### **13.2.9 Lifebuoys**

- 13.2.9.1 Lifebuoys port and starboard provided with combined self-igniting light and self-activating smoke signals should be capable of quick deployment from the navigating bridge.
- 13.2.9.2 The attached buoyant lifeline required on each of two of the lifebuoys is to have a minimum length of 30 metres.
- 13.2.9.3 Each lifebuoy should be marked with the vessel's name and Port of Registry.

### **13.2.10 EPIRB**

An approved EPIRB should be installed in an easily accessible position ready to be manually released, capable of being placed in a survival craft and floating free if the vessel sinks. All EPIRBs should be registered with the Administration. EPIRBs are to be tested annually and serviced at not more than five yearly intervals by an approved shore based maintainer.

### **13.2.11 Radar Transponders (SART)**

The SART is to be stowed in an easily accessible position so that it can rapidly be placed in any survival craft. Means should be provided in order that it can be mounted in the survival craft at a height of at least 1 metre above sea level.

### **13.2.12 General Alarm**

- 13.2.12.1 For a vessel of less than 500GT this alarm may consist of the ship's whistle or siren providing it can be heard in all parts of the vessel.
- 13.2.12.2 For a vessel of 500GT and above the requirement of 13.2.9.1 is to be supplemented by an electrically operated bell or Klaxon system, which is to be powered from the vessel's main supply and also the emergency source of power (see section 8).
- 13.2.12.3 For a vessel of 85m in length and above, in addition to the requirements of 13.2.9.2, a public address system or other suitable means of communication should be provided.

### **13.2.13 Lighting**

- 13.2.13.1 Alleyways, internal and external stairways, and exits giving access to, and including, the muster and embarkation stations should be adequately lit. (See also section 8).

13.2.13.2 Adequate lighting is to be provided in the vicinity of survival craft, launching appliance(s) (when provided) and the outside area of sea in way of the launching position(s). The lighting should be supplied from the emergency source of power.

**13.2.14 Life-saving Signals and Rescue Poster**

When display space in the wheelhouse is restricted, the 2 sides of a SOLAS No.2 poster(as contained in liferaft equipment packs) may be displayed in lieu of a SOLAS No. 1 poster.

DRAFT

## 14 FIRE SAFETY

### 14.1 Protection of spaces containing vehicles or craft with fuel in their tanks or lockers storing such fuels

14.1.1 Special consideration should be given to safe conditions of carriage of petrol and other highly flammable liquids either in hand portable containers/tanks or in the tanks of vehicles (such as personal water craft, motor cars and helicopters) which may be transported. This is not considered applicable to diesel stowage.

14.1.2 The quantity of petrol and/or other highly flammable liquids carried should be kept to a minimum, generally up to 150 litres maximum. Greater quantities may be specially considered by the Administration on receipt of a reasoned case made by the master.

14.1.3 Containers used for the carriage of flammable liquids should be constructed to a recognised standard appropriate to the contents and each container clearly marked to indicate its contents.

14.1.4 Small lockers on open deck for the stowage of hand portable containers of petrol should be located away from high risk areas, have no electrical fittings, and be provided with the following:

- 1 Natural ventilation openings top and bottom.
- 2 Drainage leading overboard.
- 3 Means of securing the fuel containers.
- 4 A facility to boundary cool the locker.

14.1.5 Enclosed spaces, and larger lockers on open deck, designated for the safe carriage of petrol or similar fuel or vehicles with fuel in their tanks should be fitted with:

- .1 A manual water spray system giving a coverage of 3.5 ltr/m<sup>2</sup>/minute over the total area of deck, which may be taken from the fire main with the isolating valve located outside the garage. An equivalent arrangement may be considered. Adequate provision should be made for drainage of water introduced to the space. This should not lead to machinery or other spaces where a source of ignition may exist.
- .2 A fixed fire detection and fire alarm system complying with the requirements of SOLAS Chapter II-2/Part A / Fire Safety Systems Code Chapter IX. The system within the space should also comply with 14.1.5.5.
- .3 Ducted mechanical exhaust ventilation, which is isolated from other ventilated spaces, should provide at least 6 air changes per hour (based on the empty space) and for which reduction of the airflow should be signalled by an audible and visual alarm on the navigating bridge and at the "in port" control station(s). Exhaust ducting should be arranged to extract from the area low over the bilge. If the fan motors are located in the space or in the ventilation duct they should be certified safe to the correct designation for the flammable vapour/liquid. The ventilation fans should be of a non-sparking type and the ventilation system should be capable of rapid shut down and effective closure in event of fire.

- .4 A suitable gas detection system is to be provided, with audible and visual alarm in the wheelhouse and where it may always be observed by the crew.
- .5 All electrical equipment located up to 450mm above the deck should be certified safe for petrol vapours.
- .6 Electrical equipment located higher than 450mm above the deck should either,
  - (a) be to [IP55] standard of construction (IEC Publication 529 - Classification of Degree of protection Provided by Enclosures). or,
  - (b) provided with easily accessible means of isolation (on all poles) located outside the space. These isolators should be grouped together as far as practicable and be clearly marked. This option should not be used for safety systems such as steering motors, rudder indicators, etc.
- .7 Regardless of the height of installation, it is considered that the following equipment located within the space should be certified safe for the flammable vapours:
  - (a) gas detection system
  - (b) bilge alarm
  - (c) fire detection system
  - (d) at least one light fitting (on a dedicated circuit, possibly emergency)

It should be noted that electrical equipment includes starters, distribution boxes, etc

## 14.2 Miscellaneous

### 14.2.1 Construction and arrangement of saunas

- 14.2.1.1 **All boundaries** of the sauna should be of "A" class **divisions**, and may include changing rooms, showers and toilets. The sauna should be insulated to A-60 for vessels of 500GT and over, A-30 for vessels under 500GT, and B-15 for Short Range Yachts, against other spaces except those inside of the perimeter.
- 14.2.1.2 Bathrooms with direct access to saunas may be considered as part of them. In such cases, the door between sauna and the bathroom need not comply with fire safety requirements.
- 14.2.1.3 Wooden linings on bulkheads and ceilings are permitted. The ceiling above the oven should be lined with a non-combustible plate with an air gap of at least 30mm. The distance from the hot surfaces to combustible materials should be at least 500mm or the combustible materials should be protected (e.g. non-combustible plate with an air gap of at least 30mm).
- 14.2.1.4 Wooden benches are permitted.
- 14.2.1.5 The sauna door should open outwards by pushing.
- 14.2.1.6 Electrically heated ovens should be provided with a timer.

14.2.1.7 All spaces within the perimeter of the sauna are to be protected by a fire detection and alarm system and an automatic sprinkler system.

#### **14.2.2 Construction and arrangement of Thermal Suite (e.g. Steam Room).**

14.2.2.1 The perimeter of the thermal suite may include changing rooms, showers and toilets.

14.2.2.2 Bathrooms with direct access to suite may be considered as part of it. In such cases, the door between suite and the bathroom need not comply with fire safety requirements.

14.2.2.3 If the steam generator is contained within the perimeter, the suite boundary should be constructed to an A-0 standard, or B-0 for Short Range Yachts. If the steam generator is not contained within the perimeter then the boundaries of the space should be constructed of B-0 class divisions, and the steam generator should be protected by A-0 standard divisions, or B-0 for Short Range Yachts.

14.2.2.4 If a suite arrangement contains a sauna then the requirements contained in 14.2.1 are applicable, regardless of the steam generator location.

14.2.2.5 All spaces within the perimeter are to be protected by a fire detection and alarm system and an automatic sprinkler.

#### **14.2.3 Deep Fat Frying Equipment**

Attention is drawn to the requirements in SOLAS II-2/10.6.4 for fire extinguishing systems for deep fat cooking equipment.

For fryers of up to 15 litres cooking oil capacity, the provision of a suitably sized Class F extinguisher (BS7937:2000) together with manual isolation of the electrical power supply is acceptable.

#### **14.3 Fire Control Plan(s)**

14.3.1 A fire control (general arrangement) plan(s) should be permanently exhibited for the guidance of the Master and crew of the vessel. The content of the plan(s) should adequately show and describe the principal fire prevention and protection equipment and materials. As far as practical, symbols used on the plans should comply with a recognised international standard. The fire control plan may be a combined Fire & Safety Plan, which should show the positions of stowage of the life-saving and fire appliances.

14.3.2 For each deck, the plan(s) should show the position of control stations; sections of the vessel which are enclosed respectively by "A" class divisions and "B" class divisions; location of flammable liquid storage (see 14.1.); particulars of and locations of fire alarms, fire detection systems, sprinkler installations, fixed and portable fire extinguishing appliances; fireman's outfit(s); means of access and emergency escapes for compartments and decks; locations and means of control of systems and openings which should be closed down in a fire emergency.

14.3.3 The plan(s) required by 14.3.1 should be kept up to date. Up-dating alterations should be applied to all copies of the plan(s) without delay. Each plan should include a list of alterations and the date on which each alteration was applied.

14.3.4 A duplicate set of the plan(s) should be permanently stored in a prominently marked weathertight enclosure readily accessible to assist non-vessel fire-fighting personnel who may board the vessel in a fire emergency.

- 14.3.5 Instructions valid to the maintenance and operation of all the equipment and installations onboard for the fighting and containment of fire should be kept in one document holder, readily available in an accessible location. For yachts over 500GT, a Fire Training Manual, as required by SOLAS Chapter II-2/15 should be provided.

DRIVER

## 14A STRUCTURAL FIRE PROTECTION - VESSELS OF LESS THAN 500GT

Objective:- The purpose of this section is to ensure a consistent level of structural fire protection. The section is primarily concerned with protecting high risk spaces such as the engine room and galley. It also makes provision for restricting the quantity of combustible materials and sets out the principles for detection of fire and effective escape.

### 14A.1 General

14A.1.1 Terms used in this section should have the same meaning as defined in SOLAS.

Table 14A.1.1 is a guide to the major requirements of this Section. The Table is intended as a quick reference to the requirements and is not to be used in isolation when designing the fire safety arrangements.

**Table 14A.1.1**

Passive fire protection (see 14A.2).	Category 'A' machinery spaces: 'A-30' (B-15 for short range yachts); Galleys B-15
Means of escape (see 14A.3):	
<ul style="list-style-type: none"> <li>Category 'A' machinery spaces.</li> <li>Accommodation and other spaces</li> </ul>	Two (2). Two (2).
Fixed fire detection system (see 14A.7).	<ul style="list-style-type: none"> <li>Fitted in machinery spaces.</li> <li>Fitted in service spaces, control stations and accommodation spaces.</li> </ul>
Automatic sprinkler system or equivalent	Fitted in yachts that do not meet restrictions on combustible materials (14A.2.3.6 & 14A.2.3.8).

### 14A.2 Structure

#### Purpose

The purpose of this section is to contain a fire in the space of origin. For this purpose, the following functional requirements should be met:

- the engine room and galley should be contained within boundaries required by this section;
- the fire integrity of the divisions should be maintained at openings and penetrations.

#### 14A.2.1 Forms of construction - Fire divisions

14A.2.1.1 Fire divisions required by 14A.2.2 are to be constructed in accordance with the remaining paragraphs of this sub-Section.

14A.2.1.2 Fire divisions using steel equivalent, or alternative forms of construction may be accepted if it can be demonstrated that the material by itself, or due to non-combustible insulation provided, has the fire resistance properties equivalent to those divisions required by 14A.2.2.1.

14A.2.1.3 Insulation required by 14A.2.1.2 is to be such that the temperature of the structural core does not rise above the point at which the structure would begin to lose its strength at anytime during the applicable exposure to the standard fire test as referenced in the IMO FTP Code. For 'A' Class divisions, the applicable exposure is 60 minutes, and for 'B' Class divisions, the applicable exposure is 30 minutes.

14A.2.1.3.1 For aluminium alloy structures, the insulation is to be such that the temperature of the structural core does not rise more than 200°C above the ambient temperature at any time during the applicable fire exposure.

14A.2.1.3.2 For composite structures, the insulation is to be such that the temperature of the laminate does not rise more than the minimum temperature of deflection under load of the resin at any time during the applicable fire exposure. The temperature of deflection under load is to be determined in accordance with a recognised international standard.

14A.2.1.3.3 Insulation need only be applied on the side that is exposed to the greatest fire risk, ie inside the engine room, a division between two such spaces should however be insulated on both sides unless it is a steel division.

14A.2.1.3.4 Special attention is to be given to the fixing of fire door frames in bulkheads constructed of materials other than steel. Measures are to be taken to ensure that the temperature of the fixings when exposed to fire does not exceed the temperature at which the bulkhead itself loses strength.

## 14A.2.2 Structural fire protection

14.A.2.2.1 (a) Machinery spaces of category 'A', are to be enclosed by 'A-30' Class boundaries. For Short Range Yachts, such machinery spaces are to be enclosed by 'B-15' Class boundaries;

(b) Yachts the keels of which are laid or are at a similar stage of construction on or after 1 January 2015 are to have galleys enclosed by 'B-15' Boundaries. It is recommended that vessels constructed before this date also comply with this requirement.

14A.2.2.2 Openings in 'A' and 'B' Class divisions are to be provided with permanently attached means of closing that are to be at least as effective for resisting fires as the divisions in which they are fitted. Generally, windows should not be fitted in machinery space boundaries.

14A.2.2.3 Where 'A' Class divisions are penetrated for the passage of electric cables, pipes, trunks, ducts, etc., or for girders, beams or other structural members, arrangements are to be made to ensure that the fire resistance is not impaired.

14A.2.2.4 Where 'B' Class divisions are penetrated for the passage of electric cables, pipes, trunks, ducts, etc., or for the fitting of ventilation terminals, lighting fixtures and similar devices, arrangements are to be made to ensure that the fire resistance is not impaired.

14A.2.2.5 Where the structure or 'A' Class divisions are required to be insulated, it is to be ensured that the heat from a fire is not transmitted through the intersections and terminal points of the divisions or penetrations to uninsulated boundaries. **Where the insulation installed does not achieve this, arrangements are to be made to prevent this heat transmission by insulating the horizontal and vertical boundaries or penetrations for a distance of 450 mm.**

### **14A.2.3 Materials**

14A.2.3.1 Except in refrigerated compartments of service spaces, all insulation (e.g. **thermal and acoustic**) is to be of not readily-ignitable materials.

14A.2.3.2 Pipes penetrating 'A' or 'B' Class divisions are to be of approved materials having regard to the temperature such divisions are required to withstand.

14A.2.3.3 Pipes conveying oil or other combustible liquids through accommodation and service spaces are to be of approved materials having regard to the fire risk.

14A.2.3.4 Materials readily rendered ineffective by heat are not to be used for overboard scuppers, sanitary discharges, and other outlets which are close to the waterline and where the failure of the material in the event of fire would give rise to danger of flooding. Due regard should be paid to the IMO Fire Test Procedures Code.

14A.2.3.5 Vapour barriers and adhesives used in conjunction with insulation, as well as insulation of pipe fittings for cold service system need not be non-combustible, but they are to be kept to the minimum quantity practicable and their exposed surfaces are to have low flame spread characteristics.

14A.2.3.6 Upholstery composites (fabric in association with any backing or padding material) used throughout the vessel should be approved in accordance with the IMO FTP Code, Annex 1, Part 8, or equivalent. This does not apply to spaces fitted with sprinklers or equivalent approved fixed fire extinguishing systems.

14A.2.3.7 **Organic foams used in upholstered furniture and mattresses should be of the combustion modified type.**

14A.2.3.8 Suspended textile materials such as curtains or drapes should be approved in accordance with the IMO FTP Code, Annex 1, Part 7, or equivalent. This does not apply to spaces fitted with sprinklers or equivalent approved fixed fire extinguishing systems.

### **14A.2.4 Surface of insulation**

In spaces where penetration of oil products is possible, the surface of insulation is to be impervious to oil or oil vapours. Insulation boundaries are to be arranged to avoid immersion in oil spillages.

### **14A.2.5 Fuel arrangements**

14A.2.5.1 Arrangements for the storage, distribution and utilisation of oil fuel are to be such as to minimise the risk of fire or explosion.

14A.2.5.2 Oil fuel tanks situated within, or adjacent to, the boundaries of Category 'A' machinery spaces are not to contain oil fuel having a flashpoint of less than 60°C.

- 14A.2.5.3 Oil fuel, lubricating oil and other flammable oils are not to be carried in fore-peak tanks.
- 14A.2.5.4 Every oil fuel pipe, which, if damaged, would allow oil to escape from a storage, settling or daily service tank situated above the double bottom, shall be fitted with a cock or valve directly on the tank capable of being closed from a safe position outside the space concerned in the event of a fire occurring in the space in which such tanks are situated.
- 14A.2.5.5 Means are to be provided to stop fuel transfer pumps, oil fired boilers and separators from outside the machinery space.
- 14A.2.5.6 Fuel filter bowls should be of metal construction.

### **14A.3 Means of escape**

#### **14A.3.1 Purpose**

The purpose of this section is to provide means of escape so that persons onboard can safely and swiftly escape to the liferaft embarkation deck. For this purpose, the following functional requirements should be met:

- safe escape routes should be provided;
- escape routes should be maintained in a safe condition, clear of obstacles; and
- additional aids for escape should be provided as necessary to ensure accessibility, clear marking, and adequate design for emergency situations.

#### **14A.3.2 Requirements**

14A.3.2.1 Stairways, ladders and corridors serving all spaces normally accessible are to be arranged so as to provide ready means of escape to a deck from which embarkation into survival craft may be effected.

14A.3.2.2 The arrangement of the vessel should be such that all compartments are provided with a satisfactory means of escape. In the case of the accommodation, two means of escape from every restricted space or group of spaces should be provided. Concealed escapes and escape routes are to be clearly marked to ensure ready exit.

Category 'A' machinery spaces on motor vessels should also be provided with a minimum of two means of escape. Other machinery spaces should also have at least two means of escape as widely separated as possible, except where the small size of the machinery space makes it impracticable.

- (a) The normal means of access to the accommodation and service spaces below the open deck is to be arranged so that it is possible to reach the open deck without passing through a galley, engine room or other space with a high fire risk, wherever practicable.
- (b) Where accommodation arrangements are such that access to compartments is through another compartment, the second escape route is to be as remote as possible from the main escape route. This may be

through hatches of adequate size, leading to the open deck or separate space to the main escape route.

- (c) In exceptional circumstances a single means of escape may be accepted for spaces, other than accommodation spaces, that are entered only occasionally, if the escape route does not pass through a galley, machinery space or watertight door.
- (d) No escape route should be obstructed by furniture or fittings. Additionally, furniture along escape routes should be secured in place to prevent shifting if the yacht rolls or lists.
- (e) All doors in escape routes are to be openable from either side. In the direction of escape they are all to be openable without a key. All handles on the inside of weathertight doors and hatches are to be non removable. Where doors are lockable measures to ensure access from outside the space are to be provided for rescue purposes.

14A.3.2.3 Lifts are not considered as forming a means of escape.

#### **14A.4 Ventilation systems**

14A.4.1 Ventilation fans for machinery spaces and enclosed galleys are to be capable of being stopped, and main inlets and outlets of ventilation systems closed, from outside the spaces being served. This position should not be readily cut off in the event of a fire in the spaces served.

14A.4.2 Ventilation ducts for Category 'A' machinery spaces, galleys, spaces containing vehicles or craft with fuel in their tanks, or lockers storing such fuels, are generally not to pass through accommodation spaces, service spaces or control stations. Where this is unavoidable, the trunking should be constructed of steel at least 3mm thick or equivalent to the satisfaction of the administration. The ducting within the accommodation should be fitted with:

- .1 fire insulation to A-30 (B-15 on Short Range Yachts) standard to a point at least 5 metres from the boundary of the machinery space or galley; and
- .2 automatic fire dampers located in the deck or bulkhead within the accommodation where the trunking passes from the machinery space or galley into the accommodation. These automatic fire dampers are also to be manually closable from outside the galley or machinery space.
- .3 **A damper at the lower end of the galley duct and fixed means for extinguishing a fire within the galley exhaust duct.**

14A.4.3 Ventilation ducts for accommodation spaces, **galleys**, service spaces or control stations are not to pass through Category 'A' machinery spaces, spaces containing vehicles or craft with fuel in their tanks, or lockers storing such fuels, unless the ducts are constructed of steel and arranged to preserve the integrity of the division.

14A.4.4 Store-rooms containing highly flammable products are to be provided with ventilation arrangements that are separate from other ventilation systems. Ventilation is to be arranged to prevent the build up of flammable vapours at high and low levels. The inlets and outlets of ventilators are to be positioned so that they do not draw from or vent into an area which would cause undue hazard, and are to be fitted with spark arresters.

14A.4.5 Ventilation systems serving Category 'A' machinery spaces are to be independent of systems serving other spaces.

14A.4.6 All enclosed spaces containing free standing fuel tanks are to be ventilated independently of systems serving other spaces.

14A.4.7 Ventilation is to be provided to prevent the accumulation of dangerous concentrations of flammable gas which may be emitted from batteries.

14A.4.8 Ducts provided for exhaust ventilation from laundries and tumble driers are to be fitted with suitably located cleaning and inspection openings.

#### **14A.5 Arrangements for gaseous fuel for domestic purposes**

14A.5.1 Where gaseous fuel is used for domestic purposes, the arrangements for the storage, distribution and utilisation of the fuel is to be such that, having regard to the hazards of fire and explosion which the use of such fuel may entail, the safety of the yacht and the persons onboard is preserved. The installation is to be in accordance with recognised National or International Standards. Hydrocarbon gas detectors and carbon monoxide detectors should be provided.

14A.5.2 Gas cylinders, regulators and safety devices should be stowed on the open deck (where leakage will not accumulate) or in a compartment that is vapour-tight to the vessels interior, and fitted with a vent and drain, so that any gas which may leak can disperse overboard.

14A.5.3 An open flame gas appliance provided for cooking, heating or any other purpose should comply with the requirements of EC Directive 90/396/EEC or equivalent.

The installation of an open flame gas appliance should comply with the appropriate provisions of Annex 3.

#### **14A.6 Space heaters**

Space heaters, if used, are to be fixed in position and so constructed as to reduce fire risks to a minimum. The design and location of these units is to be such that clothing, curtains or other similar materials cannot be scorched or set on fire by heat from the unit.

#### **14A.7 Fixed fire detection and fire-alarm systems**

14A.7.1 The purpose of this section is to detect a fire in the space of origin and to provide for an alarm for safe escape and fire-fighting activity.

14A.7.2 A fixed fire detection and fire alarm system is to be fitted in all enclosed spaces except those containing no significant fire risk (toilets, bathrooms, void spaces, etc). Manually operated call points shall be placed effectively to ensure a readily accessible means of notification. The fixed fire detection and fire-alarm system is to be installed in accordance with the requirements of SOLAS II-2/7 and the IMO

Fire Safety Systems Code, Chapter 9, **and should be audible externally.**

**14A.8 Fixed fire-extinguishing systems not required by this Section**

Where a fixed fire-extinguishing system not required by this Chapter, is installed, the arrangement is to be to the satisfaction of the Administration.

DISCLAIMER

**14B**

**STRUCTURAL FIRE PROTECTION - VESSELS OF 500GT AND OVER**

Objective: The purpose of this section is to ensure a consistent level of structural fire protection. The principles of the section aim to achieve a level of fire protection compatible with the requirements of SOLAS for passenger ships carrying up to 36 passengers. These have been adapted where appropriate to fit the general yacht design philosophy. Much emphasis is placed on the provision of sprinkler/mist systems as trade-off for certain aspects.

**14B.1**

**Definitions**

Terms used in this section should have the same meaning as defined in SOLAS, except as defined in Section 14.1 and as follows:

"Not readily ignitable" means that the surface thus described will not continue to burn for more than 20 seconds after removal of a suitable impinging test flame;

**14B.2**

**Table 14B.2 is a guide to the major requirements of this Section. The table is intended as a quick reference to the requirements and is not to be used in isolation when designing the fire safety arrangements.**

**Table 14B.2**

All vessels should comply with the following:

Form of construction (see 14B.2.1)	Steel or equivalent, or alternative forms of construction may be accepted subject to requirements.
Passive fire protection (see 14B.2.1 to 14B.2.7)	See Tables 1 and 2
Means of escape (see 14B.2.12) • Category 'A' machinery spaces • Accommodation, etc.	2 (two) 2 (two)
Fixed fire detection system (see 14B.2.14)	• Fitted in machinery spaces • Fitted in service spaces, control stations and accommodation spaces
Fire extinguishing arrangements in Category 'A' machinery spaces (see 15B)	• As per SOLAS II-2/10.5
Automatic sprinkler system or equivalent(see14B.2.14)	Fitted in all vessels

## 14B.2.1 Structure

### Purpose

The purpose of this section is to contain a fire in the space of origin. For this purpose, the following functional requirements should be met:

- the ship should be subdivided by thermal and structural boundaries;
- thermal insulation of boundaries should have due regard to the fire risk of the space and adjacent spaces;
- the fire integrity of the divisions should be maintained at openings and penetrations.

14B.2.2.1 The hull, superstructures, structural bulkheads, decks and deckhouses should be constructed of steel or other equivalent material.

14B.2.2.2 However, in cases where any part of the structure is of aluminium alloy, the following should apply:

- .1 Insulation of aluminium alloy components of "A" or "B" class divisions, except structure which, in the opinion of the Administration, is non-load-bearing, should be such that the temperature of the structural core does not rise more than 200°C above the ambient temperature at any time during the applicable fire exposure to the standard fire test. This insulation is to be applied on all sides except for the upper sides of decks and the outside of the vessel
- .2 Special attention should be given to the insulation of aluminium alloy components of columns, stanchions and other structural members required to support lifeboat and liferaft stowage, launching and embarkation areas, and "A" and "B" class divisions to ensure that for members:
  - (a) supporting lifeboat and liferaft areas and "A" class divisions, the temperature rise limitation specified in .1 above should apply at the end of one hour; and
  - (b) supporting "B" class divisions, the temperature rise limitation specified in .1 above should apply at the end of half an hour.
- .3 Aluminium alloy components of divisions that are required to be equivalent to steel (identified by an \* in tables 1 and 2) should be insulated with 25mm of mineral wool approved for use in A class divisions or with an equivalent insulation acceptable to the administration.

14B.2.2.3 For composite structures, the insulation is to be such that the temperature of the laminate does not rise more than the minimum temperature of deflection under load of the resin at any time during the specified fire exposure. The temperature of deflection under load is to be determined in accordance with the requirements of a recognised international standard. This insulation is to be applied on all sides except for the upper sides of decks and the outside of the vessel.

- .1 Special attention should be given to the insulation of composite

components of columns, stanchions and other structural members required to support lifeboat and liferaft stowage, launching and embarkation areas, and "A" and "B" class divisions to ensure that for members:

- (a) supporting lifeboat and liferaft areas and "A" class divisions, the temperature rise limitation specified in .1 above should apply at the end of one hour; and
- (b) supporting "B" class divisions, the temperature rise limitation specified in .1 above should apply at the end of half an hour.

Special attention should be given to the fixing of fire door frames in bulkheads constructed of materials other than steel. Measures are to be taken to ensure that the temperature of the fixings when exposed to fire does not exceed the temperature at which the bulkhead itself loses strength.

14B.2.2.4 Crowns and casings of a machinery space of category A should be A60 divisions and openings therein, if any, should be suitably arranged and protected to prevent the spread of fire.

14B.2.2.5 For structures in contact with sea-water, the required insulation should extend to at least 300 mm below the lightest waterline.

14B.2.2.6 Fire divisions using steel equivalent, or alternative forms of construction may be accepted if it can be demonstrated that the material by itself, or due to non-combustible insulation provided, has the fire resistance properties equivalent to the A or B class standard required.

14B.2.2.7 Insulation required by 14B.2.2.6 is to be such that the temperature of the structural core does not rise above the point at which the structure would begin to lose its strength at anytime during the applicable exposure to the standard fire test. For 'A' Class divisions, the applicable exposure is 60 minutes, and for 'B' Class divisions, the applicable exposure is 30 minutes.

### **14B.2.3 Main vertical zones and horizontal zones**

14B.2.3.1 Hull, superstructure and deckhouses in way of accommodation and service spaces should be subdivided into main vertical zones by "A" class divisions. These divisions should have insulation values in accordance with tables 1 and 2.

14B.2.3.2 As far as practicable, the bulkheads forming the boundaries of the main vertical zones above the bulkhead deck should be in line with watertight subdivision bulkheads situated immediately below the bulkhead deck. The length and width of main vertical zones may be extended to a maximum of 48 m in order to bring the ends of main vertical zones to coincide with watertight subdivision bulkheads or in order to accommodate a large public space extending for the whole length of the main vertical zone provided that the total area of the main vertical zone is not greater than 800 m<sup>2</sup> on any deck. The length or width of a main vertical zone is the maximum distance between the furthestmost points of the bulkheads bounding it.

14B.2.3.3 Such bulkheads should extend from deck to deck and to the shell or other boundaries.

14B.2.3.4 When a main vertical zone is subdivided by "A" class divisions for the purpose of providing an appropriate barrier between spaces protected and not protected by

a sprinkler system, the divisions should be insulated in accordance with the fire insulation and integrity values given in tables 1 and 2.

#### **14B.2.4 Bulkheads within a main vertical zone**

14B.2.4.1 All bulkheads within accommodation and service spaces which are not required to be "A" class divisions should be at least "B" class or "C" class divisions as prescribed in the tables 1 and 2.

14B.2.4.2 All such divisions may be faced with combustible materials

14B.2.4.3 All corridor bulkheads, where not required to be "A" class should be "B" class divisions which should extend from deck to deck except:

- .1 when continuous "B" class ceilings or linings are fitted on both sides of the bulkhead, the portion of the bulkhead behind the continuous ceilings or lining should be of material which, in thickness and composition, is acceptable in the construction of "B" class divisions but which should be required to meet "B" class integrity standards only in so far as is reasonable and practical in the opinion of the Administration;
- .2 the corridor bulkheads of "B" class materials may terminate at a ceiling in the corridor provided such a ceiling is of material which, in thickness and composition, is acceptable in the construction of "B" class divisions. All doors and frames in such bulkheads should be so constructed and erected to provide a "B" class standard.

14B.2.4.4 All bulkheads required to be "B" class divisions, except corridor bulkheads, should extend from deck to deck and to the shell or other boundaries unless continuous "B" class ceilings or linings are fitted on both sides of the bulkhead, in which case the bulkhead may terminate at the continuous ceiling or lining.

#### **14B.2.5 Fire integrity of bulkheads and decks**

14B.2.5.1 In addition to complying with the specific provisions for fire integrity of bulkheads and decks mentioned elsewhere in this section, the minimum fire integrity of bulkheads and decks should be as prescribed in tables 1 and 2.

14B.2.5.2 The following requirements should govern application of the tables:

- .1 Tables 1 and 2 should apply respectively to the bulkheads and decks separating adjacent spaces.
- .2 For determining the appropriate fire integrity standards to be applied to divisions between adjacent spaces, such spaces are classified according to their fire risk as shown in categories (1) to (9) below. The title of each category is intended to be typical rather than restrictive. The number in parentheses preceding each category refers to the applicable column or row in the tables.
  - (1) *Control stations*
    - Spaces containing emergency sources of power and lighting.
    - Wheelhouse and chartroom.
    - Spaces containing the vessel's radio equipment.
    - Fire-extinguishing rooms.
    - Fire control rooms and fire-recording stations .
    - Control room for propulsion machinery when located outside the

- machinery space.
- Spaces containing centralized fire alarm equipment.
- (2) *Corridors and lobbies*
  - Guest and crew corridors and lobbies.
- (3) *Accommodation spaces*
  - Cabins, dining rooms, lounges, offices, pantries containing no cooking appliances (other than equipment such as microwave cookers and toasters), and similar spaces.
- (4) *Stairways*
  - Interior stairways, lifts and escalators (other than those wholly contained within the machinery space(s)) and enclosures thereto.
  - In this connection, a stairway which is enclosed only at one level should be regarded as part of the space from which it is not separated by a fire door.
- (5) *Service spaces (low risk)*
  - Lockers and store-rooms not having provisions for the storage of flammable liquids and having areas less than 4m<sup>2</sup>, and drying rooms and laundries.
- (6) *Machinery spaces of category A,*
  - Spaces so defined.
- (5) *Other machinery spaces*
  - Spaces so defined, excluding machinery spaces of category A.
  - Sprinkler, drencher or fire pump spaces.
- (6) *Service spaces (high risk)*
  - Galleys, pantries containing cooking appliances, paint and lamp rooms, lockers and store-rooms having areas of 4<sup>m</sup> or more, spaces for the storage of flammable liquids, workshops other than those forming part of the machinery spaces, and spaces containing vehicles or craft with fuel in their tanks, or lockers storing such fuels storage lockers for gaseous fuels for domestic purposes.
- (7) *Open decks*
  - Open deck spaces and enclosed promenades having no fire risk. Air spaces (the space outside superstructures and deckhouses).

14B.2.5.3 Continuous "B" class ceilings or linings, in association with the relevant decks or bulkheads, may be accepted as contributing, wholly or in part, to the required insulation and integrity of a division.

14B.2.5.4 External boundaries which are required to be of steel or other equivalent material may be pierced for the fitting of windows and portlights provided that there is no requirement for such boundaries to have "A" class integrity elsewhere in this section. Similarly, in such boundaries which are not required to have "A" class integrity, doors may be of combustible materials, substantially constructed.

**Table 1 - Fire integrity of bulkheads separating adjacent spaces**

Spaces	(1)	(2)	(3)	(4)	(5)	(6)	(7)	(8)	(9)
Control stations (1)	A-0 <sub>c</sub>	A-0	A-60	A-0	A-15	A-60	A-15	A-60	*
Corridors and lobbies (2)		C <sub>d</sub>	B-0 <sub>d</sub>	A-0 <sub>a</sub> B-0 <sub>d</sub> O <sub>d</sub>	B-0 <sub>d</sub>	A-60	A-0	A-0	*
Accommodation spaces (3)			C <sub>d</sub>	A-0 <sub>a</sub> B-0 <sub>d</sub>	B-0 <sub>d</sub>	A-60	A-0	A-0	*
Stairways (4)				A-0 <sub>a</sub> B-0 <sub>d</sub>	A-0 <sub>a</sub> B-0 <sub>d</sub>	A-60	A-0	A-0	*
Service spaces (low risk) (5)					C <sub>d</sub>	A-60	A-0	A-0	*
Machinery spaces of category A (6)						*	A-0	A-60	*
Other machinery spaces (7)							A-0 <sub>b</sub>	A-0	*
Service spaces (high risk) (8)								A-0 <sub>b</sub>	*
Open decks (9)									

**Table 2 - Fire integrity of decks separating adjacent spaces**

<b>Spaces above</b> <b>Spaces below</b>	(1)	(2)	(3)	(4)	(5)	(6)	(7)	(8)	(9)
Control stations (1)	A-0	A-0	A-0	A-0	A-0	A-60	A-0	A-0	*
Corridors and lobbies (2)	A-0	*	*	A-0	*	A-60	A-0	A-0	*
Accommodation spaces (3)	A-60	A-0	*	A-0	*	A-60	A-0	A-0	*
Stairways (4)	A-0	A-0	A-0	*	A-0	A-60	A-0	A-0	*
Service spaces (low risk) (5)	A-15	A-0	A-0	A-0	*	A-60	A-0	A-0	*
Machinery spaces of (6)category A	A-60	A-60	A-60	A-60	A-60	*	A-60 <sub>e</sub>	A-60	*
Other machinery spaces (7)	A-15	A-0	A-0	A-0	A-0	A-0	*	A-0	*
Service spaces (high risk) (8)	A-60	A-0	A-0	A-0	A-0	A-60	A-0	A-0	*
Open decks (9)	*	*	*	*	*	*	*	*	-

Notes: To be applied to both tables 1 and 2, as appropriate.

- a For clarification on which applies, see 14B.2.4 and 14B.2.6.
- b Where spaces are of the same numerical category and subscript <sub>b</sub> appears, a bulkhead or deck of the rating shown in the tables is only required when the adjacent spaces are for a different purpose, e.g in category (9). A galley next to a galley does not require a bulkhead but a galley next to a paint room requires an "A-0" bulkhead.
- c Bulkheads separating the wheelhouse and chartroom from each other may be "B-0" rating.
- d For the application of 14B.2.3.1, "B-O" and "C", where appearing in table 1, should be read as "A-0".
- e Fire insulation need not be fitted if the machinery space in category (7), in the opinion of the Administration, has little or no fire risk.
- \* Where an asterisk appears in the tables, the division is required to be of steel or other equivalent material but is not required to be of "A" class standard.

For the application of 14B.2.3.1 an asterisk, where appearing in table 2, except for category (9), should be read as "A-0".

## **14B.2.6 Protection of stairways and lifts in accommodation and service spaces**

14B.2.6.1 A stairway should be of steel frame construction except where the Administration sanctions the use of other equivalent material, and should be within enclosures formed of "A" class divisions, with positive means of closure at all openings, except that:

- .1 an isolated stairway which penetrates a single deck only may be protected at one level only by at least "B" class divisions and self-closing door(s); and
- .2 stairways may be fitted in the open in a public space, provided they lie wholly within such public space.

14B.2.6.2 A stairway enclosure should have direct communication with the corridors and be of sufficient area to prevent congestion, having in view the number of persons likely to use them in an emergency. In so far as is practical, stairway enclosures should not give direct access to galleys, machinery spaces, service lockers, or other enclosed spaces containing combustibles in which a fire is likely to originate.

14B.2.6.3 A lift trunk should be so fitted to prevent the passage of flame from one 'tween-deck to another and should be provided with means of closing to permit the control of draught and smoke.

## **14B.2.7 Openings in "A" class divisions**

14B.2.7.1 Except for hatches between store and baggage spaces, and between such spaces and the weather decks, all openings should be provided with permanently attached means of closing which should be at least as effective for resisting fires as the divisions in which they are fitted.

14B.2.7.2 The construction of all doors and door frames in "A" class divisions, with the means of securing them when closed, should provide resistance to fire as well as the passage of smoke and flame, as far as practical, equivalent to that of the bulkheads in which the doors are situated.

Such doors and door frames should be constructed of steel or other equivalent material. **Sliding** steel watertight doors need not be insulated.

14B.2.7.3 It should be possible for each door to be opened and closed from each side of the bulkhead by one person only.

14B.2.7.4 Fire doors in main vertical zone bulkheads, galley boundaries and stairway enclosures other than power-operated watertight doors and those which are normally locked, should satisfy the following requirements:

- (a) the doors should be self-closing and be capable of closing with an angle of inclination of up to  $3.5^\circ$  opposing closure;
- (b) the approximate time of closure for hinged fire doors should be no more than 40 seconds and no less than 10 seconds from the beginning of their movement with the ship in the upright position. The approximate uniform rate of closure for sliding doors should be of no more than 0.2 m/s and no less than 0.1 m/s with the ship in the upright position;
- (c) the doors, except those for emergency escape trunks, should be capable of remote release from the continuously manned central control station, either simultaneously or in groups and should also be capable of release, individually, from a position at the door. Release switches should have an on-off function to prevent automatic resetting of the system;
- (d) hold-back hooks not subject to central control station release are prohibited;
- (e) a door closed remotely from the central control station should be capable of being re-opened from both sides of the door by local control. After such local opening, the door should automatically close again;
- (f) indication must be provided at the fire door indicator panel in the continuously manned central control station whether each door is closed;
- (g) the release mechanism should be so designed that the door will automatically close in the event of disruption of the control system or central power supply;
- (h) local power accumulators for power-operated doors should be provided in the immediate vicinity of the doors to enable the doors to be operated after disruption of the control system or central power supply at least ten times (fully opened and closed) using the local controls;
- (i) disruption of the control system or central power supply at one door should not impair the safe functioning of the other doors;
- (j) remote-released sliding or power-operated doors should be equipped with an alarm that sounds at least 5s but no more than 10s after the door being released from the central control station and before the door begins to move and continues sounding until the door is completely closed;
- (k) a door designed to re-open upon contacting an object in its path should re-open not more than 1 m from the point of contact;
- (l) double-leaf doors equipped with a latch necessary for their fire integrity should have a latch that is automatically activated by the operation of the

doors when released by the system;

- (m) the components of the local control system should be accessible for maintenance and adjusting;
- (n) power-operated doors should be provided with a control system of an approved type which should be able to operate in case of fire and be in accordance with the Fire Test Procedures Code. This system should satisfy the following requirements:
  - the control system should be able to operate the door at the temperature of at least 200°C for at least 60 min, served by the power supply;
  - the power supply for all other doors not subject to fire should not be impaired; and
  - at temperatures exceeding 200°C the control system should be automatically isolated from the power supply and should be capable of keeping the door closed up to at least 945°C.

14B.2.7.5 Where 'A' Class divisions are penetrated for the passage of electric cables, pipes, trunks, ducts, etc., or for girders, beams or other structural members, arrangements are to be made to ensure that the fire resistance is not impaired.

#### **14B.2.8 Openings in "B" class divisions**

14B.2.8.1 Doors and door frames in "B" class divisions and means of securing them should provide a method of closure which should have resistance to fire as far as practical equivalent to that of the divisions except that a ventilation opening may be permitted in the lower portion of such doors. When such an opening is in or under a door the total net area of the opening(s) should not exceed 0.05m<sup>2</sup>. When such an opening is cut in a door it should be fitted with a grill made of non-combustible material. Doors should be noncombustible or of substantial construction.

14B.2.8.2 Where 'B' Class divisions are penetrated for the passage of electric cables, pipes, trunks, ducts, etc., or for the fitting of ventilation terminals, lighting fixtures and similar devices, arrangements are to be made to ensure that the fire resistance is not impaired.

#### **14B.2.9 Windows and portlights (Also see 5.4 and 5.5)**

14B.2.9.1 All windows and portlights in bulkheads within accommodation spaces, service spaces and control stations should be so constructed to preserve the integrity requirements of the type of bulkheads in which they are fitted.

14B.2.9.2 Glass is not to be installed as an interior main vertical zone, stairway enclosure bulkhead, or within machinery space boundaries.

#### **14B.2.10 Details of construction**

14B.2.10.1 In accommodation and service spaces, control stations, corridors and stairways:

- .1 air spaces enclosed behind ceilings, panelling or linings should be suitably divided by close-fitting draught stops not more than 14m apart; and
  - .2 in the vertical direction, enclosed air spaces, including those behind linings of stairways, trunks, etc should be closed at each deck.
- 14B.2.10.2 The draught stops are to be non-combustible and are to form a continuation above the ceiling of the bulkhead below or the other side of the panelling or lining to the bulkhead, as far as possible.
- 14B.2.10.3 Where the structure or 'A' Class divisions are required to be insulated, it is to be ensured that the heat from a fire is not transmitted through the intersections and terminal points of the divisions or penetrations to uninsulated boundaries. Where the insulation installed does not achieve this, arrangements are to be made to prevent this heat transmission by insulating the horizontal and vertical boundaries or penetrations for a distance of 450 mm.
- 14B.2.10.4 Without impairing the efficiency of the fire protection, the construction of ceilings and bulkheads should allow a fire patrol to detect any smoke originating in concealed and inaccessible places, except where there is no risk of fire originating in such places.
- 14B.2.10.5 When gaseous fuel is used for domestic purposes, the arrangements for the storage, distribution and utilisation of the fuel should be such that, having regard to the hazards of fire and explosion which the use of such fuel may entail, the safety of the vessel and the persons onboard are preserved.

In particular, open flame gas appliances provided for cooking, heating or any other purposes, should comply with the requirements of EC directive 90/396/EEC or equivalent and, the installation of open flame gas appliances should comply with the appropriate provisions of Section 14A.5.

**14B.2.11 Restricted use of combustible materials**

- 14B.2.11.1 Except in spaces protected by an automatic sprinkler system and fully addressable fire detection system in accordance with 14B.2.14, all linings, grounds, and ceilings should be of non-combustible materials.
- 14B.2.11.2 Insulation materials should be non-combustible, however core insulation of refrigerator and cold rooms need not be. Vapour barriers and adhesives used in conjunction with insulation, as well as insulation of pipe fittings for cold service systems need not be non-combustible, but they should be kept to the minimum quantity practicable and their exposed surfaces should have low flame spread characteristics.
- 14B.2.11.3 The following surfaces should be low flame spread:
- .1 exposed surfaces in corridors and stairway enclosures, and of bulkheads, wall and ceiling linings in all service spaces and control stations; and
  - .2 concealed or inaccessible spaces in accommodation, service spaces and control stations.

As an alternative to .1 and .2 above, these spaces may contain surfaces that are not low flame spread, provided

- .3 adequate barriers of low flame spread surfaces are arranged to restrict the spread of flame areas at distances not greater than 5m, or
  - .4 these spaces are protected by an automatic sprinkler system and fully addressable fire detection system in accordance with 14B.2.14.
- 14B.2.11.4 Pipes penetrating 'A' or 'B' Class divisions are to be of approved materials having regard to the temperature such divisions are required to withstand.
- 14B.2.11.5 Pipes conveying oil or combustible liquids through accommodation and service spaces are to be of approved materials having regard to the fire risk.
- 14B.2.11.6 Materials readily rendered ineffective by heat are not to be used for overboard scuppers, sanitary discharges, and other outlets which are close to the waterline and where the failure of the material in the event of fire would give rise to the danger of flooding.
- 14B.2.11.7 Furniture in the corridors and escape routes should be of a type and quantity not likely to obstruct access. Additionally, furniture along escape routes should be secured in place to prevent shifting if the vessel rolls or lists.
- 14B.2.11.8 Primary deck coverings within accommodation spaces, service spaces and control stations are to be of a type which will not readily ignite, or give rise to toxic or explosive hazards at elevated temperatures. Reference is also to be made to the IMO FTP Code, Annex 1, Parts 2 and 6.
- 14B.2.11.9 Except when a fully addressable fire detection system is fitted, upholstery composites (fabric in association with any backing or padding material) used throughout the vessel should be approved in accordance with the IMO FTP Code, Annex 1, Part 8 or an equivalent standard acceptable to the administration.
- 14B.2.11.10 Except when a fully addressable fire detection system is fitted bedding components should be approved in accordance with the IMO FTP Code, Annex 1, Part 9 or an equivalent standard acceptable to the administration.
- 14B.2.11.11 Except when a fully addressable fire detection system is fitted, suspended textile materials such as curtains and drapes should be approved in accordance with the IMO FTP Code, Annex 1, Part 7, or an equivalent standard, acceptable to the administration.
- 14B.2.11.12 Upholstery, bedding components and suspended textiles required to comply with the IMO FTP code or an equivalent standard are to be clearly labelled by the manufacturer stating the standard that they meet and any washing or cleaning instructions needed to maintain their fire resistance. These labels are not to be removed.
- 14B.2.11.13 In spaces where penetration of oil products is possible, the surface of insulation is to be impervious to oil or oil vapours. Insulation boundaries are to be arranged to avoid immersion in oil spillages so far as is practicable.

## 14B.2.12 Means of escape

### Purpose

The purpose of this section is to provide means of escape so that persons

onboard can safely and swiftly escape to the lifeboat and liferaft embarkation deck. For this purpose, the following functional requirements should be met:

- safe escape routes should be provided;
- escape routes should be maintained in a safe condition, clear of obstacles; and
- additional aids for escape should be provided as necessary to ensure accessibility, clear marking, and adequate design for emergency situations.

14B.2.12.1 Stairways and ladders should be arranged to provide ready means of escape to the lifeboat and liferaft embarkation deck from all guest and crew accommodation spaces and service spaces in which the crew are normally employed, other than machinery spaces. In particular, the following provisions should be complied with:

- .1 Below the bulkhead deck two means of escape, at least one of which should be independent of watertight doors, should be provided from each watertight compartment, main vertical zone or similarly restricted group of spaces. Exceptionally one of the means of escape may be dispensed with, due regard being paid to the nature and location of spaces and to the number of persons who might normally be accommodated or employed there.
- .2 Above the bulkhead deck, there are to be at least two means of escape from each vertical fire zone or similarly restricted spaces or group of spaces, at least one of which is to give access to a readily accessible escape which will provide continuous fire shelter from the level of its origin to the appropriate survival craft embarkation deck
- .3 Within each main vertical zone there should be at least one readily accessible enclosed stairway providing continuous fire shelter, where practical, at all levels up to the appropriate lifeboat and liferaft embarkation decks or the highest level served by the stairway, whichever level is the highest. The width, number and continuity of the stairways should be satisfactory for the number of persons likely to use them.
- .4 Access from the stairway enclosures to the lifeboat and liferaft embarkation areas should avoid high fire risk areas.
- .5 Stairways serving only a space and a balcony in that space should not be considered as forming one of the required means of escape.
- .6 If a radio room or wheelhouse has no direct access to the open deck, two means of escape should be provided, one of which may be a window of sufficient size or another means.
- .7 Stairways are not to exceed **3.5m** vertical rise without the provision of a landing.
- .8 In the case where direct access to the appropriate survival craft embarkation deck as required by .1 and .2 is not practical, a readily accessible escape which will provide continuous fire shelter from the level

of its origin to the appropriate open deck with subsequent direct passage to the embarkation deck can be accepted provided that these escape routes including external staircases, have emergency lighting and slip free surfaces under foot.

- .9 Protection of access from the stairway enclosures to the lifeboat and liferaft embarkation areas should be provided either directly or through protected internal routes which have fire integrity and insulation values for stairway enclosures as determined by tables 1 and 2, as appropriate.
- .10 Where public spaces span three or more open decks and contain combustibles such as furniture and give access to other enclosed spaces, each level within the space is to have two means of escape, one of which is to give access to a readily accessible escape which will provide continuous fire shelter from the level of its origin to the appropriate survival craft embarkation deck.

14B.2.12.2 Two means of escape should be provided from each machinery space. In particular, the following provisions should be complied with:

- .1 The two means of escape should consist of either:
  - (a) two sets of steel ladders as widely separated as possible, leading to doors in the upper part of the space similarly separated and from which access is provided to the appropriate survival craft embarkation decks. One of these ladders should provide continuous fire shelter from the lower part of the space to a safe position outside the space. This shelter is to be of steel or equivalent material, insulated where necessary, and provided with a self closing door at the lower end. If access is provided at other levels each level is to be provided with a steel or equivalent material self-closing door; or
  - (b) one steel ladder leading to a door in the upper part of the space from which access is provided to the embarkation deck and additionally, in the lower part of the space and in a position well separated from the ladder referred to, a steel door capable of being operated from each side and which provides access to a safe escape route from the lower part of the space to the embarkation deck.

- .2 One of the means of escape from any such space required by 14B.2.12.2.1 may be dispensed with on sailing vessels with small machinery spaces, so long as either a door or a steel ladder and walkways provide a safe escape route to the embarkation deck with due regard being paid to the nature and location of the space and whether persons are normally employed in that space.
  - .3 Two means of escape should be provided from a machinery control room located within a machinery space, at least one of which should provide continuous fire shelter to a safe position outside the machinery space.
- 14B.2.12.3 Lifts should not be considered as forming one of the required means of escape.
- 14B.2.12.4 In exceptional circumstances a single means of escape may be accepted for spaces other than accommodation spaces that are entered only occasionally, if the escape route does not pass through a galley, machinery space or watertight door.
- 14B.2.12.5 Adequate deck area is to be provided at assembly stations and embarkation areas having due regard to the expected number of persons. Generally, assembly stations should be provided close to the embarkation stations. Each assembly station should have sufficient clear deck space to accommodate all persons assigned to assemble at that station, but at least 0.35m<sup>2</sup> per person.

#### **14B.2.12.6 Emergency Escape Breathing Devices**

Emergency escape breathing devices (EEBD's) should comply with the Fire Safety Systems Code. At least one spare emergency escape breathing device should be kept onboard.

- 14B.2.12.6.1 All vessels should carry at least two EEBD's within accommodation spaces, and at least two EEBD's should be carried in each main vertical zone.
- 14B.2.12.6.2 On all vessels, within the machinery spaces, EEBD's should be situated ready for use at easily visible locations, which can be reached quickly and easily at any time in the event of fire. The number and location should take into account the layout of the machinery space and the number of persons normally working in the space. The number and location of these devices should be indicated in the fire control plan.

#### **14B.2.13 Ventilation systems**

- 14B.2.13.1 Ventilation ducts should be of non-combustible material. Short ducts, however, not generally exceeding 2m in length and with a cross-section not exceeding 0.02m<sup>2</sup> need not be non-combustible, subject to the following conditions:
- .1 they should be of a suitable material having regard to the risk of fire;
  - .2 they should be used only at the end of the ventilation device; and
  - .3 they should not be situated less than 600mm, measured along the duct, from an opening in an "A" or "B" class division including continuous "B" class ceilings.
- 14B.2.13.2 Where ventilation ducts with a free cross-sectional area exceeding 0.02m<sup>2</sup> pass through class "A" bulkheads or decks, the opening should be lined with a steel

sheet sleeve unless the ducts passing through the bulkheads or decks are of steel in the vicinity of passage through the deck or bulkhead and the ducts and sleeves should comply in this part with the following:

- .1 Sleeves should have a thickness of at least 3mm and a length of at least 900mm. When passing through bulkheads, this length should be divided preferably into 450mm on each side of the bulkhead. The ducts, or sleeves lining such ducts, should be provided with fire insulation. The insulation should have at least the same fire integrity as the bulkhead or deck through which the duct passes.
- .2 Ducts with a free cross-sectional area exceeding  $0.075\text{m}^2$  should be fitted with fire dampers in addition to the requirements of .1 above. The fire damper should operate automatically but should also be capable of being closed manually from both sides of the bulkhead or deck. The damper should be provided with an indicator which shows whether the damper is open or closed.

Fire dampers are not required, however, where ducts pass through spaces surrounded by "A" class divisions, without serving those spaces, provided those ducts have the same fire integrity as the divisions which they pierce.

14B.2.13.3 Ducts provided for the ventilation of a machinery space of **category A, galley**, spaces containing vehicles or craft with fuel in their tanks or lockers storing such fuel, should not pass through accommodation spaces, service spaces or control stations unless they comply with the conditions specified in .1 to .4 or .5 and .6 below:

- .1 they are constructed of steel having a thickness of at least 3mm and 5mm for duct widths or diameters of up to and including 300mm and 760mm and over respectively and, in the case of ducts with widths or diameters between 300mm and 760mm, thickness should be obtained by interpolation;
- .2 they are suitably supported and stiffened;
- .3 they are fitted with automatic fire dampers close to the boundaries penetrated; and
- .4 they are insulated to "A-60" standard from a machinery space or galley to a point at least 5m beyond each fire damper; or
- .5 they are constructed of steel in accordance with .1 and .2 above; and
- .6 they are insulated to "A-60" standard throughout accommodation spaces, service spaces or control stations; except that penetrations of main zone divisions should also comply with the requirements of 14B.2.13.8.

- 14B.2.13.4 Ducts provided for ventilation to accommodation spaces, service spaces or control stations, should not pass through a machinery space of **category A, galley**, spaces containing vehicles or craft with fuel in their tanks or lockers storing such fuel, unless they comply with the conditions specified in .1 to .3 or .4 and .5 below:
- .1 where they pass through a machinery space of category A or galley, ducts are constructed of steel in accordance with 14B.2.13.3.1 and .2;
  - .2 automatic fire dampers are fitted close to the boundaries penetrated; and
  - .3 the integrity of the machinery space or galley boundaries is maintained at penetrations or;
  - .4 where they pass through a machinery space of category A or galley, ducts are constructed of steel in accordance with 14B.2.13.3.1 and .2; and
  - .5 within a machinery space **of category A** or galley, ducts are insulated to "A-60" standard; except that penetrations of main zone divisions should also comply with the requirements of 14B.2.13.8.
- 14B.2.13.5 Ventilation ducts with a free cross-sectional area exceeding 0.02m<sup>2</sup> passing through "B" class bulkheads should be lined with steel sheet sleeves of 900mm in length divided preferably into 450mm on each side of the bulkheads, unless the duct is of steel for this length.
- 14B.2.13.6 For a control station outside machinery spaces and other normally manned control stations, practical measures should be taken to ensure that ventilation, visibility and freedom from smoke are maintained so that, in the event of fire, the machinery and equipment contained in the control station may be supervised and continue to function effectively. Alternative and separate means of air supply should be provided; air inlets of the two sources of supply should be so disposed that the risk of both inlets drawing in smoke simultaneously is minimized. These requirements need not apply to control stations situated on, and opening on to, an open deck, or where local closing arrangements would be equally effective.
- 14B.2.13.7 Exhaust duct(s) from a galley range should be constructed of "A" class divisions where passing through accommodation spaces and/or spaces containing combustible materials. In addition to the requirements of 14B.2.13.3 an exhaust duct should be fitted with:
- .1 a grease trap readily removable for cleaning;
  - .2 a fire damper located in the lower end of the duct;
  - .3 **arrangements for shutting off the exhaust fans;**
  - .4 fixed means for extinguishing a fire within the duct.
  - .5 **Local controls to activate extinguishing system; stop the fans and close the fire dampers should be grouped in one position immediately outside the main entrance to the galley.**
- 14B.2.13.8 When it is necessary for a ventilation duct to pass through a main vertical zone division, a fail-safe automatic closing fire damper should be fitted adjacent to the division. The damper should also be capable of being manually closed from each side of the division. The operating position should be readily accessible and be marked in red light-reflecting colour. The duct between the division and the damper should be of steel or other equivalent material and, if necessary, insulated to comply with the requirements of SOLAS regulation II-2/9.3.1. The damper should be fitted on at least one side of the division with a visible indicator

showing whether the damper is in the open position.

- 14B.2.13.9 Inlets and outlets of ventilation systems should be capable of being closed from outside the space being ventilated.
- 14B.2.13.10 Power ventilation of accommodation spaces, service spaces, control stations and machinery spaces should be capable of being stopped from an easily accessible position outside the space being served. This position should not be readily cut off in the event of a fire in the spaces served. The means provided for stopping the power ventilation of a machinery space should be entirely separate from the means provided for stopping ventilation of other spaces.
- 14B.2.13.11 Where public spaces span three or more open decks and contain combustibles such as furniture, and other enclosed spaces, the space is to be equipped with a smoke extraction system. The smoke extraction system is to be activated by the smoke detection system required by 14B.2.14 and is to be capable of manual control. The fans are to be capable of exhausting the entire volume within the space in not more than 10 min.
- 14B.2.13.12 Store-rooms containing highly flammable products are to be provided with ventilation arrangements that are separate from other ventilation systems. Ventilation is to be arranged to prevent the build up of flammable vapours at high and low levels. The inlets and outlets of ventilators are to be positioned so that they do not draw from or vent into an area which would cause undue hazard, and are to be fitted with spark arresters.
- 14B.2.13.13 Ventilation systems serving Category 'A' machinery spaces are to be independent of systems serving other spaces.
- 14B.2.13.14 All enclosed spaces containing free standing fuel tanks are to be ventilated independently of systems serving other spaces.
- 14B.2.13.15 Ventilation is to be provided to prevent the accumulation of dangerous concentrations of flammable gas which may be emitted from batteries.
- 14B.2.13.16 Ventilation openings may be fitted in and under the lower parts of cabin and public space doors in corridor bulkheads. The total net area of any such openings is not to exceed 0.05m<sup>2</sup>.
- 14B.2.13.17 For spaces containing vehicles or craft with fuel in their tanks or lockers storing such fuels, see 14.1.5. For additional requirements for the ventilation of domestic gaseous fuel, see 14A.5.
- 14B.2.13.18 Ducts provided for exhaust ventilation from laundries and tumble driers are to be fitted with suitable located cleaning and inspection openings.
- 14B.2.13.19 All fire dampers should comply with IMO Resolution A.754(18) pt A11 as referenced in IMO FTP Code , Annex 1, Part 3.
- 14B.2.14 Fixed fire detection and fire alarm systems and automatic sprinkler, fire detection and fire alarm systems**

#### **Purpose**

The purpose of this section is to detect a fire in the space of origin and to provide for alarm for safe escape and fire-fighting activity. For this purpose, the following functional requirements should be met:

- fixed fire detection and fire alarm system installations should be suitable for the nature of the space, fire growth potential and potential generation of smoke and gases; and
- manually operated call points should be placed effectively to ensure a readily accessible means of notification.

14B.2.14.1 Each separate zone in all accommodation and service spaces, except spaces which afford no substantial fire risk such as void spaces, sanitary spaces, etc., should be provided throughout with an automatic sprinkler, fire detection and fire alarm system of an approved type and complying with the requirements of SOLAS 74, Chapter II-2 Part C, regulation II-2/7 and the IMO FSS Code, Chapter 8, or an equivalent standard acceptable to the Administration. The system should be designed to enable simultaneous operation of all sprinklers fitted in the most hydraulically demanding area. The minimum area for simultaneous operation may be taken as the largest area bounded by "A-O" class bulkheads or the breadth of the vessel squared, whichever is the greater, subject to a maximum of 280m<sup>2</sup>.

14B.2.14.2 A fixed fire detection and fire alarm system is to be fitted in all enclosed spaces except those containing no significant fire risk (toilets, bathrooms, void spaces, etc). Manually operated call points shall be placed effectively to ensure a readily accessible means of notification. The fixed fire detection and fire-alarm system is to be installed in accordance with the requirements of SOLAS II-2/7 and the IMO Fire Safety Systems Code, Chapter 9, and should be audible externally.

#### 14B.2.15 Public Address System

14B.2.15.1 For vessels having a length of 85 m or more, a public address system complying with the requirements of SOLAS 74, Chapter III, regulation 6.5 is to be available throughout the accommodation and service spaces and control stations and open decks.

#### 14B.2.16 Oil fuel arrangements

14B.2.16.1 Arrangements for the storage, distribution and utilisation of oil fuel are to be such as to minimise the risk of fire or explosion.

14B.2.16.2 As far as practicable, oil fuel tanks are to be part of the vessel's structure and are to be located outside Category 'A' machinery spaces.

14B.2.16.3 Where oil fuel tanks, other than double bottom tanks, are necessarily located adjacent to or within Category 'A' machinery spaces, at least one of their vertical sides is to be contiguous to the machinery space boundaries, and is preferably to have a common boundary with the double bottom tanks, and the area of the tank boundary common with the machinery spaces is to be kept to a minimum. Where the vertical boundary of a tank directly exposed to a machinery space meets the vessel's side plating at an acute angle, a small horizontal surface at the base of the tank, necessary to accommodate practical constructional considerations may be permitted. If the arrangement of the machinery is such that a tank with a large horizontal surface at the base is necessary then a cofferdam with suitable ventilation arrangements, to protect the base of the tank from the effect of a machinery space fire, will be specially considered. Oil fuel tanks situated within the boundaries of Category 'A' machinery spaces are not to contain oil fuel having a flashpoint of less than 60°C. Except for vessels constructed of materials other than steel, where steel tanks should be provided, the use of free standing oil fuel tanks is prohibited.

**14B.2.17 Lubricating oil arrangements**

**14B.2.17.1** Arrangements for the storage, distribution and utilisation of oil used in pressure lubrication systems are to be such as to minimise the risk of fire or explosion.

**14B.2.18 Arrangements for other flammable oils**

**14B.2.18.1** Arrangements for the storage, distribution and utilisation of other flammable oils employed under pressure in power transmission systems, control and activating systems and heating systems are to be such as to minimise the risk of fire or explosion.

**14B.2.19 Prohibition of carriage of flammable oils in forepeak tanks**

**14B.2.19.1** Oil fuel, lubricating oil and other flammable oils are not to be carried in forepeak tanks.

**14B.2.20 Arrangements for gaseous fuel for domestic purposes**

**14B.2.20.1** Where gaseous fuel is used for domestic purposes, the arrangements for the storage, distribution and utilization of the fuel are to be such that, having regard to the hazards of fire and explosion which the use of such fuel may entail, the safety of the vessel and the persons on board is preserved. The installation is to be in accordance with recognised national or international standards and is to meet the requirements contained in 14A.5.

**14B.2.21 Space heaters**

**14B.2.21.1** Space heaters, if used, are to be fixed in position and so constructed as to reduce fire risks to a minimum. The design and location of these units is to be such that clothing, curtains or other similar materials cannot be scorched or set on fire by heat from the unit.

**15A FIRE APPLIANCES - VESSELS OF LESS THAN 500GT**

**15A.1 General Requirements**

- 15A.1.1 Fire appliances are to be of an approved type and should be provided to meet the minimum requirements listed in Table 1 and the specific requirements of 15A.2.
- 15A.1.2 Fire appliances provided in addition to those required by 15A.1.1 should be of a type acceptable to the Administration.
- 15A.1.3 The location of concealed fire appliances should be clearly marked.

**Table 1 - FIRE APPLIANCES - VESSELS OF LESS THAN 500GT**

1	PROVISION OF WATER JET – sufficient to reach any part of vessel	1
2	POWER DRIVEN FIRE PUMP - engine or independent drive	1
3	ADDITIONAL INDEPENDENT POWER DRIVEN FIRE PUMP, POWER SOURCE AND SEA CONNECTION - not located in the same space as item 2	1
4	FIREMAIN & HYDRANTS -	Sufficient to achieve item 1 with a single length of hose
5	HOSES - with jet/spray nozzles each fitted with a shut-off facility	3
6	FIRE EXTINGUISHERS - portable,(accommodation and service spaces)	For each deck, 1 within 10m of any position within an accommodation or service space
7	FIRE EXTINGUISHERS - for a machinery space of <b>Category A</b> - the options are:  (a) a fixed fire extinguishing system approved in accordance with the IMO Fire Safety Systems Code; and  (b) (i) 1 portable extinguisher for oil fires for each 74.6kw power; or (ii) 2 portable extinguishers for oil fires together with either  1 foam extinguisher of 45l capacity; or  1 CO2 extinguisher of 16kg capacity	7 (max)  2 + 1
8	FIREMANS OUTFIT - to include an approved breathing apparatus <b>for each outfit</b>	<b>2</b>
9	FIRE BLANKET - in galley	1

**15A.2 Specific Requirements**

**15A.2.1 Provision of water jet**

At least one jet of water, from a single length of hose, should be able to reach any part of the vessel normally accessible to passengers or crew while the vessel is being navigated and, any store room or any part of a storage compartment when empty.

## 15A.2.2 Fire pumps

15A.2.2.1 The power driven fire pump should have a capacity of

$$2.5 \times \{1 + 0.066 \times (L(B+D))^{0.5}\}^2 \text{ m}^3/\text{hour}$$

where:

L = the length

B = the greatest moulded breadth

D = the moulded depth measured to the bulkhead deck at amidships.

When discharging at full capacity through 2 adjacent fire hydrants, the pump should be capable of maintaining a water pressure of 0.2N/mm<sup>2</sup> at any hydrant, provided the fire hose can be effectively controlled at this pressure.

15A.2.2.2 The second fire pump, which may be portable, should have a capacity of at least 80% of that required by 15A.2.2.1 and be capable of input to the fire main. A permanent sea connection, external to the machinery space, should be provided. "Throw-over" sea suctions are not acceptable.

15A.2.2.3 Each centrifugal fire pump should be provided with a non-return valve in the connection to the fire main.

## 15A.2.3 Fire main and hydrants

15A.2.3.1 A fire main, water service pipes and fire hydrants should be fitted.

15A.2.3.2 The fire main and water service pipe connections to the hydrants should be sized for the maximum discharge rate of the pump(s) connected to the main.

15A.2.3.3 The fire main, water service pipes and fire hydrants should be constructed such that they will:

- .1 not be rendered ineffective by heat;
- .2 not readily corrode; and
- .3 be protected against freezing.

15A.2.3.4 When a fire main is supplied by 2 pumps, 1 in the machinery space and 1 elsewhere, provision should be made for isolation of the fire main within the machinery space and for the second pump to supply the fire main and hydrants external to the machinery space. Isolation valve(s) should be manually operated valves fitted outside the machinery space in a position easily accessible in the event of a fire.

15A.2.3.5 The fire main should have no **permanent** connections other than those necessary for fire fighting or washing down.

15A.2.3.6 Fire hydrants should be located for easy attachment of fire hoses, protected from damage and distributed so that a single length of the fire hoses provided can reach any part of the vessel.

15A.2.3.7 Fire hydrants should be fitted with valves that allow a fire hose to be isolated and

removed when a fire pump is operating.

#### **15A.2.4 Fire hoses**

15A.2.4.1 Fire hoses should not exceed 18 metres in length and, generally, the diameter of a lined hose for use with a powered pump should not be less than 45mm.

15A.2.4.2 Fire hoses and associated tools and fittings should be kept in readily accessible and known locations, close to the hydrants or connections on which they will be used. Hoses supplied from a powered pump should have jet/spray nozzles (incorporating a shut-off facility) of diameter 19mm, 16mm or 12mm depending on fire fighting purposes. For accommodation and service spaces, the diameter of nozzles need not exceed 12mm. For machinery spaces and exterior locations, the nozzle size should be as to obtain the maximum discharge possible from two jets at the pressure referred to in 15A.2.2.1, from the smallest pump.

15A.2.4.3 Hydrants or connections in interior locations on the vessel should have hoses connected at all times. For use within accommodation and service spaces, proposals to provide a smaller diameter of hoses and jet/spray nozzles will be considered.

15A.2.4.4 The number of fire hoses and nozzles provided should correspond to the functional fire safety requirements, but be at least 3.

#### **15A.2.5 Portable fire extinguishers for use in accommodation and service spaces**

15A.2.5.1 The number, location, fire extinguishing medium type and capacity should be selected according to the perceived fire risk, but for each deck, one portable extinguisher should be available for use within a distance of 10m from any location. A minimum of at least 3 portable fire extinguishers should be provided. As far as practical, the fire extinguishers provided should have a uniform method of operation and should be of an approved **5kg/9 litre** type and capacity.

15A.2.5.2 Portable fire extinguishers of the carbon dioxide type should not be located or provided for use in accommodation spaces.

15A.2.5.3 Except for portable extinguishers provided in connection with a specific hazard within a space when it is manned (such as a galley), portable extinguishers generally should be located external to, but adjacent to, the entrance of the space(s) in which they will be used. Extinguishers should be stowed in readily accessible and marked locations.

15A.2.5.4 Spare charges should be provided onboard for at least 50% of each type and capacity of portable fire extinguisher onboard. When an extinguisher is not of a type which is rechargeable when the vessel is at sea, an additional portable fire extinguisher of the same type (or its equivalent) should be provided.

#### **15A.2.6 Fire extinguishing in machinery spaces**

15A.2.6.1 In a category A machinery space containing internal combustion type machinery, fire appliances should be provided at least to the extent listed in item 7 of Table 1 - Fire Appliances.

15A.2.6.2 In a machinery space containing an oil fired boiler, oil fuel settling tank or oil fuel unit, a fixed fire extinguishing system complying with the IMO Fire Safety Systems Code should be installed.

15A.2.6.3 Portable fire extinguishers should be installed and the number, location, fire extinguishing medium type and capacity should be selected according to the perceived fire risk in the space. (Spare charges or spare extinguishers should be provided per 15A.2.5.4.)

In any case, portable fire extinguishers for extinguishing oil fires should be fitted:

- .1 in a boiler room - at least 2;
- .2 in a space containing any part of an oil fuel installation - at least 2;  
and
- .3 in a firing space - at least 1.

**15B**

**FIRE APPLIANCES - VESSELS OF 500GT AND OVER**

All vessels should comply with the requirements of SOLAS 74, Chapter II-2, regulation 10. as may be amended, and as appropriate to the vessel and its equipment. For the purpose of the SOLAS regulations, the standards for a cargo ship apply.

In no case should the standards applied be less than those applied to a vessel of less than 500GT.

The location of concealed fire appliances should be clearly marked.

**DRAFT**

## **16 RADIO**

### **16.1 Application**

16.1.1 This section applies to all vessels.

### **16.2 Radio communications: The Global Maritime Distress and Safety System (GMDSS)**

16.2.1 Each vessel should carry sufficient radio equipment to perform the following distress and safety communications functions throughout its intended voyage.

- .1 transmitting ship to shore distress alerts by at least two separate and independent means, each using a different radio communication service;
- .2 receiving shore-to-ship distress alerts;
- .3 transmitting and receiving ship-to-ship distress alerts;
- .4 transmitting and receiving search and rescue co-ordinating communications;
- .5 transmitting and receiving on-scene communications;
- .6 transmitting and receiving signals for locating by radar;
- .7 transmitting and receiving maritime safety information; and
- .8 transmitting and receiving bridge-to-bridge communications.

16.2.2 Existing vessels should carry sufficient radio equipment for distress and safety communications to the satisfaction of the Administration. The radio equipment carried should not be less than that specified in Table 1 of this section.

16.2.3 Notwithstanding the requirements in Table 1 of this section, it is strongly recommended that existing vessels regardless of size should carry the radio equipment according to the area of operation specified in Table 2.

## 16.3 Radio Installations

16.3.1 Table 1 illustrates the minimum radio installations to be carried by an existing vessel sailing at different distances from a safe haven.

**Table 1**

Radio Equipment	Distance from safe haven – nautical miles			
	Up to 30	Up to 60	Up to 150	Unlimited
VHF Radio telephone with Digital Selective Calling (DSC)	One	One	One	One
MF/HF Radio Telephone with Digital Selective Calling (DSC)	None	Note <sup>3</sup>	One <sup>1</sup>	One <sup>1</sup>
INMARSAT Ship Earth Station	None	None	One <sup>1</sup>	One <sup>1</sup>
NAVTEX receiver	None	None	One <sup>2</sup>	One <sup>2</sup>

Notes:

1. An INMARSAT Ship Earth Station OR a MF/HF radiotelephone with DSC may be fitted for operations over 60 miles from a safe haven. When a vessel operates north of 70 degrees North, or south of 70 degrees South, an INMARSAT Ship Earth Station and MF/HF is required due to lack of coverage also, IRIDIUM is recommended.
2. If the vessel is sailing in an area where an international NAVTEX service is not provided then the NAVTEX receiver should be supplemented by an INMARSAT enhanced group calling system.
3. For existing vessels it is strongly recommended that MF/HF DSC option is fitted to cover the distance between 30nm and 60nm from a safe haven.

16.3.2 Example:

As an illustration, the minimum equipment to be installed on an existing vessel operating worldwide would be:

one VHF radiotelephone with DSC;  
one INMARSAT –C ship earth station  
one NAVTEX receiver  
one MF/HF radiotelephone with DSC

Note: The requirements for the carriage of two way radiotelephone sets, EPIRBs and SARTs are given in chapter 13, table 1. EPIRBs for vessels operating in Sea Area A4 are to be capable of operating through the polar orbiting satellite service in the 406 MHz band.

16.3.3 Table 2 illustrates the minimum radio installations to be carried by new vessels the keels of which were laid or are at a similar stage of construction on or after [1 January 2013] and on vessels subject to major conversion. This fulfils the distress and safety communication functions for voyages in Sea Areas A1, A2, A3 and A4.

**Table 2**

A1	A1+A2	A1+A2+A3		A1+A2+A3+A4
		either	Or	
NAVTEX <sup>1</sup>	NAVTEX <sup>1</sup>	NAVTEX <sup>1</sup>	NAVTEX <sup>1</sup>	NAVTEX <sup>1</sup>
VHF (DSC) Radiotelephone	VHF (DSC) Radiotelephone	VHF (DSC) Radiotelephone	VHF (DSC) Radiotelephone	VHF (DSC) Radiotelephone
---	MF (DSC) Radiotelephone <sup>2</sup>	MF (DSC) Radiotelephone	MF/HF (DSC) Radiotelephone <sup>2</sup>	MF/HF (DSC) Radiotelephone <sup>2</sup>
---	---	INMARSAT C Ship Earth Station		

Notes:

1 If the vessel is sailing in an area where an international NAVTEX service is not provided then the NAVTEX receiver should be supplemented by an additional means of receiving MSI transmissions such as the Inmarsat enhanced group calling system.

2 Incorporating direct-printing telegraphy or an alternative means of receiving MSI transmissions in the Sea Areas in which the vessel is operating.

The requirements for the carriage of two way radiotelephone sets, EPIRBs and SARTs are given in Section 13, Table 1. EPIRBs for vessels operating in Sea Area A4 are to be capable of operating through the polar orbiting satellite service in the 406 MHz band.

## 16.4 Operational Performance

16.4.1 All radio communication equipment required by this section should be of a type which is approved by the relevant authority.

## 16.5 Installation

16.5.1 All radio installations should:

- .1 be so located to ensure the greatest possible degree of safety and operational availability;
- .2 be protected against the harmful effects of water, extremes of temperature and other adverse environmental conditions;
- .3 be clearly marked with the call sign, the vessel station identity and any other codes applicable to the use of the radio installation.

## **16.6 Sources of energy**

16.6.1 Vessels <300GT should have sufficient reserve energy supply to operate the radio installations for a minimum of 3 hours in addition to the emergency supply.

16.6.2 Vessels ≥300GT but <500GT NOT meeting the emergency source of electrical energy requirements of SOLAS II-1/Part D, Regulation 43, should have sufficient reserve energy supply to operate the radio installations for a minimum of 6 hours in addition the emergency supply.

16.6.3 All vessels ≥300 GT meeting the emergency the requirements of SOLAS II-1/D, Regulation 43 should have a one hour reserve supply

16.6.3 When a reserve source of energy consists of a rechargeable accumulator battery, a means of automatically charging such batteries should be provided, which is capable of recharging them to minimum capacity requirements within 10 hours which should include a visual and audible charger failure device.

16.6.4 The siting and installation of accumulator batteries should ensure the highest degree of service and safety.

## **16.7 Watches**

16.7.1 A vessel, while at sea, should maintain a continuous watch:

- .1 where practicable, on VHF Channel 16;
- .2 where practicable, on VHF Channel 13;
- .3 on VHF Digital Selective Calling (DSC), on Channel 70;
- .4 if fitted with a MF/HF radiotelephone, on distress and safety DSC frequency 2187.5kHz;
- .5 for satellite shore-to-ship distress alerts, if fitted, with a radio facility for reception of marine safety information by the INMARSAT enhanced group calling system; and
- .6 for broadcasts of marine safety information on the appropriate frequency or frequencies, on which such information is broadcast for the area in which the vessel is navigating; normally using the international NAVTEX service or INMARSAT's enhanced group calling facility. (Further information may be obtained from the Admiralty List of Radio Signals volume 5.)

## **16.8 Radio Personnel**

16.8.1 A vessel should carry at least one person qualified for distress and safety radiocommunication purposes, who should hold a certificate of competence acceptable to the relevant authority.

## **16.9 Availability of equipment**

16.9.1 On vessels of 300GT and above the availability of radio installations should be ensured by using such methods as duplication of equipment, shore-based maintenance or at sea electronic maintenance capability.

**17 NAVIGATION LIGHTS, SHAPES AND SOUND SIGNALS**

- 17.1 Every vessel should comply with the requirements of the International Regulations For Preventing Collisions At Sea, 1972, as amended.
- 17.2 All navigation lights should be provided with main and emergency power supply.
- 17.3 With due regard to accessibility, the requirement for duplication for navigation lights required to be shown whilst underway may be satisfied by having a spare lamp that can be easily fitted within three minutes. **However, on yachts over 500GT these must be duplicate lights.**
- 17.4 For vessels where compliance is impracticable, alternatives may be considered by application to the Administration.

## 18 NAVIGATIONAL EQUIPMENT AND VISIBILITY FROM WHEELHOUSE

### 18.1 Navigational Equipment

18.1.1 A vessel should be fitted with the following:

- .1 A properly adjusted standard magnetic compass or other means, independent of any power supply, to determine the ship's heading.
- .2 In a steel vessel, it should be possible to correct the compass for coefficients B, C and D, and heeling error
- .3 The magnetic compass or repeater should be so positioned as to be clearly readable by the helmsman at the main steering position. It should also be provided with an electric light, the electric power supply of which should be of the twin wire type.

18.1.2 A vessel should be fitted with, the following additional equipment:

- .1 an echo sounder;
- .2 a receiver for a global navigation satellite system or a terrestrial radio-navigation system, or other means suitable for use at all times throughout the intended voyage, to establish and update the ship's position by automatic means;
- .3 speed and distance measuring device, or other means, to indicate speed and distance through the water;
- .4 a gyro compass or spare magnetic compass bowl;
- .5 a rudder angle indicator; and
- .6 a 9 GHz radar.

18.1.3 For vessels of less than 300GT the equipment specified in 18.1.1 and 18.1.2 need not be of an approved type.

18.1.4 Means should be provided for taking bearings as near as practicable over an arc of the horizon of 360°. This requirement may be met by the fitting of a pelorus compass, or, on a vessel other than a steel vessel, with a hand bearing compass.

18.1.5 For vessels under 300GT the requirements of 18.1.2.4 may be met by the use of a fluxgate compass, provided that a suitable back up power supply is available to power the compass in the event of failure of the main electrical supply. Where such a compass incorporates a capability to measure magnetic deviation by undertaking a calibration routine, and where the deviation figures are recorded within the device, a deviation card is not required.

18.1.6 Attention should be paid to magnetic effects on magnetic compasses, including fluxgate compasses, when operating in Polar Regions. (i.e. north of 70° N, or south of 70° S).

18.1.7 All vessels of 300GT and over shall be fitted with an approved automatic identification system (AIS) in accordance with SOLAS Chapter V, no later than 31st December 2004. The AIS shall:

- .1 provide automatically to appropriately equipped shore stations, other ships and aircraft, information including the ships identity, type, position, course, speed, navigational status and other safety related information;
- .2 receive automatically such information from similarly fitted ships
- .3 monitor and track ships; and
- .4 exchange data with shore- based facilities.

18.1.8 All vessels of 300GT and over, unless operating solely within sea area A1, shall be capable of Long-Range Identification and Tracking (LRIT) in accordance with SOLAS Chapter V, no later than 31<sup>st</sup> December 2008.

The required shipborne equipment should as a minimum:

- .1 be capable of automatically, and without human intervention on board the ship, transmitting the ship's LRIT information at 6-hour intervals to an LRIT Data Centre;
- .2 be capable of being configured remotely to transmit LRIT information at variable intervals;
- .3 be capable of transmitting LRIT information following receipt of polling commands;
- .4 interface directly to the shipborne global navigation satellite system equipment, or have internal positioning capability;
- .5 be supplied with energy from the main and emergency source of electrical power; and
- .6 be tested for electromagnetic compatibility taking into account the recommendations developed by the IMO.

The current list of Authorised Testing Application Service Providers (ATASP's) are contained in Marine Information Note MIN 343, as may be amended.

18.1.9 All vessels shall be fitted with a bridge navigational watch alarm system (BNWAS), in accordance with SOLAS Chapter V as follows:

18.1.9.1 Vessels of 150 gross tonnage and upwards constructed on or after 1 July 2011;

18.1.9.2 Vessels of 500 gross tonnage and upwards but less than 3,000 gross tonnage constructed before 1 July 2011, not later than the first survey after 1 July 2013; and

18.1.9.3 Vessels of 150 gross tonnage and upwards but less than 500 gross tonnage constructed before 1 July 2011, not later than the first survey after 1 July 2014.

18.1.9.4 A bridge navigational watch alarm system (BNWAS) installed prior to 1 July 2011 may subsequently be exempted from full compliance with the standards adopted by the IMO, at the discretion of the Administration.

The bridge navigational watch alarm system shall be in operation whenever the ship is underway at sea.

**18.2 Bridge Visibility**

18.2.1 Navigation bridge visibility should comply with SOLAS Chapter V. Vessels under 55m in length should comply as far as reasonable and practicable.

18.2.2 Windows may be inclined from the vertical plane provided that, where necessary, appropriate measures are taken to avoid adverse reflections from within.

18.2.3 Windows to the navigating position should not be of either polarised or tinted glass (see 5.5.8) Portable tinted screens may be provided for selected windows.

## **19 MISCELLANEOUS EQUIPMENT**

### **19.1 Nautical Publications**

Every vessel should carry nautical charts and nautical publications to plan and display the ship's route for the intended voyage and to plot and monitor positions throughout the voyage.

An approved electronic chart display and information system (ECDIS) may be accepted as meeting these chart carriage requirements.

Back-up arrangements to meet these functional requirements should be provided where this function is partly or fully filled by electronic means: this means single ECDIS and paper charts or duplicate ECDIS.

### **19.2 Measuring Instruments**

Every vessel should carry a barometer. Every sailing vessel should carry an anemometer and an inclinometer.

### **19.3 Signalling Lamp**

Every vessel should carry a daylight signalling lamp, or other means to communicate by light during day and night using an energy source of electrical power not solely dependent upon the ship's power supply. The signalling lamp may be the searchlight required by 19.4.

### **19.4 Searchlight**

Every vessel should carry an efficient fixed or portable searchlight suitable for man-overboard search and rescue operations.

**19.5** Vessels of <150 GT require a radar reflector.

**19.6** Vessels of >300 GT must be marked externally with the vessel's IMO number which may be horizontal provided that it is visible from the air.

Objective:- The purpose of this section is to set out the minimum standard for anchoring and mooring arrangements. It should be noted that this element is to be an integral part of the Classification process and this should be reflected in the Class Notation.

**20.1 Equipment**

20.1.1 Vessels will be considered to have adequate equipment if fitted out in accordance with standards for such equipment, set by an approved Classification Society.

20.1.2 Vessels not equipped in accordance with 20.1.1 may be specially considered by the Administration, provided full information is submitted for approval.

20.1.3 All vessels are to have at least 2 anchors, one of which must be ready for use at all times. Any powered deployment system should be connected to an emergency power supply or be capable of being manually operated.

**20.2 Sailing Vessels**

20.2.1 The sizing of anchors and cables for sailing vessels should take into account the additional windage effect of the masts and rigging.

20.2.2 Typically, for square rigged sailing vessels, experience based guidance on approximate increase in anchor mass and cable strength required is:

for vessels up to 50 metres in length, typically 50% above the requirements for a typical motor vessel having the same total longitudinal profile area of hull and superstructure as the square rigged sailing vessel under consideration; and

for vessels 100 metres in length and over, typically 30% above the requirements for a typical motor vessel having the same total longitudinal profile area of hull and superstructure as the square rigged sailing vessel under consideration.

For a square rigged sailing vessel of between 50 and 100 metres in length the increase should be obtained by linear interpolation.

## **21 ACCOMMODATION**

### **21.1 General**

21.1.1 **This section applies to vessels to which sections 21A and 21B do not apply.**

21.1.2 An adequate standard of accommodation should be provided to ensure the comfort, recreation, health and safety of all persons on board.

21.1.3 Attention is drawn to the achievement of appropriate standards for means of access and escape, lighting, heating, food preparation and storage, messing, safety of movement about the vessel, ventilation and water services.

21.1.4 Generally, accommodation standards for the crew should be at least equivalent to the standards set by the International Labour Organisation conventions for crew accommodation in merchant ships. The ILO Convention provisions should be practicable with regard to vessels greater than 500GT. For smaller vessels, particularly sailing vessels, the standards should be applied where possible. When it is neither reasonable nor practicable to site crew sleeping accommodation amidships or aft, and above the deepest waterline as required, measures taken to ensure an equivalent level of crew health and safety should be agreed with the Administration. Sleeping accommodation with the deckhead lining below the deepest waterline is not permitted. It is recommended that where such accommodation is sited partially below the deepest waterline it should be arranged such that in the event of damage to the watertight compartment in which the accommodation space is situated, the lining should not be immersed.

21.1.5 Crew accommodation should not be sited within hazardous spaces.

The following standards are described by general principles which need to be expanded to meet the requirements which relate to the use and areas of operation of particular vessels.

### **21.2 Access/Escape Arrangements**

See 14A.3 and 14B.2.12.

### **21.3 Lighting**

An electric lighting system should be installed which is capable of supplying adequate light to all enclosed accommodation and working spaces. The system should be designed and installed in accordance with section 8.

### **21.4 Heating**

As considered appropriate, an adequate heating installation should be provided.

### **21.5 Food Preparation, Storage and Messing**

21.5.1 The galley floor should be provided with a non-slip surface and provide a good foothold.

21.5.2 All furniture and fittings in the galley shall be made of a material which is impervious to dirt and moisture. All metal parts of furniture and fittings shall be rust resistant.

21.5.3 The ventilation in the galley shall be arranged to ensure that there is an adequate

supply of fresh air and for the efficient discharge of fumes into the open air (see also 21.7).

21.5.4 When a cooking appliance is gimballed it should be protected by a crash bar or other means to prevent personal injury. Means should be provided to lock the gimbaling mechanism.

21.5.5 Means should be provided to allow the cook to be secured in position, with both hands free for working, when the vessel motions threaten safe working.

21.5.6 Secure and hygienic storage for food and garbage should be provided.

21.5.7 A messing area(s) should be provided, each messing area shall be large enough to accommodate the greatest number of persons likely to use it at any one time.

## **21.6 Hand Holds and Grab Rails**

There should be sufficient hand holds and grab rails within the accommodation to allow safe movement around the accommodation at all times. Stairways should be specially considered

## **21.7 Ventilation**

21.7.1 Effective means of ventilation should be provided to all enclosed spaces which are entered by personnel.

21.7.2 Mechanical ventilation should be provided to all accommodation spaces on vessels which are intended to make long international voyages or operate in tropical waters. As a minimum, mechanical ventilation should be capable of providing 6 changes of air per hour, when all access and other openings (other than ventilation intakes) to the spaces are closed.

21.7.3 Air conditioning systems are to provide a minimum of 25m<sup>3</sup> of air per hour, per person accommodated in the ventilated space during normal operating conditions.

21.7.4 Enclosed galleys are to be specially considered, and where air conditioning is not fitted should have, as a minimum, a mechanical supply of 20 fresh air changes per hour and a mechanical exhaust of 30 changes.

## **21.8 Water Services**

21.8.1 An adequate supply of fresh drinking water should be provided and piped to convenient positions throughout the accommodation spaces.

21.8.2 In addition, an emergency reserve supply of drinking water should be carried, sufficient to provide at least 2 litres per person. The installation of fresh water making machines and disinfection arrangements are to be to the acceptance of the Administration (for this purpose silver ionisation or chlorination would be considered acceptable).

## **21.9 Sleeping Accommodation**

21.9.1 An appropriately sized bed (bunk or cot) **minimum inside dimensions 1.98m x 0.80m** should be provided for every person on board, with due regard for the guidance produced by the International Labour Organization (ILO). Where considered appropriate, means for preventing the occupants from falling out,

should be provided.

There shall be no direct access into sleeping rooms from spaces for machinery, galleys, paint rooms or from engine, deck, and other bulk storerooms, drying rooms, communal wash places or water closets.

21.9.2 In crew accommodation, wherever possible, the maximum number of persons per sleeping room is to be two and there should be unobstructed access to at least one side of each bed. Any increase in the maximum number of persons per sleeping room should be agreed with the Administration

## **21.10 Toilet Facilities**

21.10.1 Adequate sanitary toilet facilities should be provided on board. The facilities should be at least one water closet, one shower for every 8 persons or part thereof, and one washbasin for every 6 persons or part thereof.

21.10.2 In vessels where a sanitary system, including a holding tank, is provided, care should be taken to ensure that there is no possibility of fumes from the tank finding their way back to a toilet, should the water seal at the toilet be broken.

## **21.11 Stowage Facilities for Personal Effects**

Adequate stowage facilities for clothing and personal effects should be provided for every person on board.

## **21.12 Securing of Heavy Equipment**

All heavy items of equipment such as ballast, batteries, cooking stove, etc, should be securely fastened in place. All stowage lockers containing heavy items should have lids or doors which are capable of being securely fastened.

**21A ACCOMMODATION AND RECREATIONAL FACILITIES – VESSELS OF LESS THAN 200GT BUILT ON OR AFTER THE [Date of coming into force of MLC 2006]**

Objective: The purpose of this section is to implement substantially equivalent arrangements to the crew accommodation requirements of the Maritime Labour Convention 2006 to vessels built after the coming into force of the Convention on the [date of coming into force]. The aim of the Convention is to provide a comprehensive set of global maritime labour standards for all seafarers, including accommodation standards.

**21A.1 General**

21A.1.1 Vessels of less than 200GT that do not trade internationally are excepted from the requirements of this section and should comply with Section 21.

21A.1.2 Accommodation should provide decent living conditions and recreational facilities for those persons employed or engaged in any work capacity onboard. The accommodation should also be adequate for those who are not seafarers onboard the vessel.

21A.1.3 In order to provide decent living conditions and recreational facilities the following requirements are provided as minimum standards.

21A.1.4 The materials used to construct internal bulkheads, panelling and sheeting, floors and joinings should be suitable for the purpose and conducive to ensuring a healthy environment.

21A.1.5 Excessive noise and vibration should be limited within accommodation spaces, and as far as practicable in accordance with relevant international standards. Where the seafarers' exposure to noise and vibration is very time limited in accommodation spaces, alternative arrangements may be accepted.

**21A.2 Access/Escape Arrangements**

21A.2.1 See 14A.3 and 14B.2.12.

**21A.3 Headroom**

21A.3.1 There should be adequate and reasonable headroom for all seafarers on board taking into consideration the size and operation of vessel. Headroom provided should not result in discomfort to the seafarers onboard.

21A.3.2 For spaces where seafarers are expected to stand for prolonged periods, the minimum headroom should be 190 centimetres. The competent authority may allow reduced height in some locations if it does not result in discomfort to seafarers.

## **21A.4 Ventilation**

- 21A.4.1 Effective means of ventilation should be provided to all enclosed spaces which are entered by personnel.
- 21A.4.2 Mechanical ventilation should be provided to all accommodation spaces on vessels which are intended to make long international voyages or operate in tropical waters. As a minimum, mechanical ventilation should be capable of providing 6 changes of air per hour, when all access and other openings (other than ventilation intakes) to the spaces are closed.
- 21A.4.3 Air conditioning systems are to provide a minimum of 25m<sup>3</sup> of air per hour, per person accommodated in the ventilated space during normal operating conditions.
- 21A.4.4 Enclosed galleys are to be specially considered, and where air conditioning is not fitted should have, as a minimum, a mechanical supply of 20 fresh air changes per hour and a mechanical exhaust of 30 changes.
- 21A.4.5 In spaces where sanitary facilities are provided there should be ventilation that draws from the accommodation and extracts to the open air independent of the other parts of the accommodation.

## **21A.5 Heating and insulation**

- 21A.5.1 All accommodation spaces should be adequately heated, taking into account climatic conditions. The accommodation should be adequately insulated.

## **21A.6 Lighting**

- 21A.6.1 An electric lighting system should be installed which is capable of supplying adequate light to all enclosed accommodation and working spaces. The system should be designed and installed in accordance with section 8.
- 21A.6.2 Seafarer's sleeping rooms and mess rooms should be lit by natural light and provided with adequate artificial light. Where the provision of natural light is impracticable, adequate artificial light may be acceptable in limited areas.

## **21A.7 Water services and provision**

- 21A.7.1 Hot and cold running fresh water should be available in all wash places.
- 21A.7.2 An adequate supply of fresh drinking water should be provided and piped to convenient positions throughout the accommodation spaces.
- 21A.7.3 In addition, an emergency reserve supply of drinking water should be carried, sufficient to provide at least 2 litres per person. The installation of fresh water making machines and disinfection arrangements are to be to the acceptance of the Administration (for this purpose silver ionisation or chlorination would be considered acceptable).

## **21A.8 Galley facilities and provision of food.**

21A.8.1 Adequate food should be provided for all seafarers onboard free of charge. The provision of food should take account of the seafarers' religious requirements and cultural practices, the nature and duration of the voyage, and should be suitable in respect of quantity, nutritional value, quality and variety.

21A.8.2 The organisation and equipment of the catering department should be such as to permit the provision to the seafarers of adequate, varied and nutritious meals prepared and served in hygienic conditions. This should include as a minimum that the galley is fitted with a means of cooking and a sink and have adequate working surface for the preparation of food. The galley floor should be provided with a non-slip surface and provide a good foothold.

21A.8.3 All furniture and fittings in the galley should be made of a material which is impervious to dirt and moisture. All metal parts of furniture and fittings should be rust resistant.

21A.8.4 The ventilation in the galley should be arranged to ensure that there is an adequate supply of fresh air and for the efficient discharge of fumes into the open air (see also 21A.4.4).

21A.8.5 When a cooking appliance is gimballed it should be protected by a crash bar or other means to prevent personal injury. Means should be provided to lock the gimbaling mechanism.

21A.8.6 Means should be provided to allow the cook to be secured in position, with both hands free for working, when the vessel motions threaten safe working.

21A.8.7 Secure and hygienic storage for food and garbage should be provided.

21A.8.8 A messing area(s) should be provided, each messing area should be large enough to accommodate the greatest number of persons likely to use it at any one time.

## **21A.9 Hand Holds and Grab Rails**

21A.9.1 There should be sufficient hand holds and grab rails within the accommodation to allow safe movement around the accommodation at all times. Stairways should be specially considered.

## **21A.10 Sleeping accommodation**

21A.10.1 Sleeping accommodation should be of adequate size and properly equipped so as to ensure reasonable comfort and to facilitate tidiness.

21A.10.2 There should be no direct access into sleeping rooms from spaces for machinery, galleys, paint rooms or from engine, deck, and other bulk storerooms, drying rooms, communal wash places or water closets.

21A.10.3 In seafarer accommodation, wherever possible, the maximum number of persons per sleeping room is to be two and there should be unobstructed access to at least one side of each bed. Any increase in the maximum number of persons per sleeping room should be agreed with the Administration.

21A.10.4 Sleeping accommodation should be situated or equipped, as practicable, so as to provide appropriate levels of privacy for men and for women.

- 21A.10.5 Berths for seafarers must have a minimum inside dimension of either:
- .1 not less than 190 centimetres by 70 centimetres, with no tapering, where it is satisfied that that this is reasonable and will not result in discomfort to the seafarers; or
  - .2 not less than 198 centimetres by 80 centimetres, where a taper is permitted from half the length of the berth so that under no circumstances the berth is narrower than 50 centimetres.
- 21A.10.6 Where considered appropriate, means for preventing the occupants from falling out, should be provided.
- 21A.10.7 Sleeping rooms should be situated above the load line/freeboard mark amidships or aft (or the maximum loaded displacement where no load line/freeboard mark is provided), but in no case forward of the collision bulkhead.
- 21A.10.8 Where it is not possible to provide sleeping accommodation above the load line/freeboard mark (or the maximum loaded displacement where no load line/freeboard mark is provided) as required by 21A.10.7, there should be an alarm fitted to provide early warning of flooding that alerts occupants of the sleeping accommodation and provides them with sufficient time to escape from the accommodation.
- 21A.11 Sanitary facilities**
- 21A.11.1 There must be at least one set of sanitary facilities for each 6 seafarers onboard, separated from the rest of the accommodation. Each set of sanitary facilities should include one shower or one tub, one wash basin and one toilet. Each set of sanitary facilities must be provided with a door that is lockable. Where reasonable and practicable there should be separate sanitary facilities provided for men and for women.
- 21A.11.2 In vessels where a sanitary system, including a holding tank, is provided, care should be taken to ensure that there is no possibility of fumes from the tank finding their way back to a toilet, should the water seal at the toilet be broken.
- 21A.12 Mess rooms**
- 21A.12.1 It may be that the mess will be a shared facility for seafarers and passengers in most cases. Mess rooms should be of adequate size and comfort and properly furnished and equipped (including ongoing facilities for refreshment), taking account of the number of seafarers and passengers likely to use them at any one time.
- 21A.13 Recreational facilities**
- 21A.13.1 Appropriate seafarers' recreational facilities, amenities and services, as adapted to meet the special needs of seafarers who must live and work onboard should be provided.
- 21A.13.2 All vessels should have a space or spaces on open deck to which the seafarers can have safe access when off duty, which are of adequate area having regard to the size of the ship and the number of seafarers onboard, and are protected from the elements. Due consideration should be given to any areas of deck

which may be considered as posing a safety risk to seafarers. Such spaces may be shared with the passengers onboard.

#### **21A.14 Stowage facilities for personal effects**

21A.14.1 Each seafarer should be provided with adequate storage space for personal effects which must be a minimum of 125 litres per seafarer.

#### **21A.15 Machinery space boundaries**

21A.15.1 Where machinery spaces are adjacent to accommodation spaces, the boundaries should be designed to be as gas tight as reasonable and practicable.

21A.15.2 Machinery space boundaries must retain any liquids which may leak from the equipment within the machinery space.

#### **21A.16 Securing of Heavy Equipment**

21A.16.1 All heavy items of equipment such as ballast, batteries, cooking stove, etc, should be securely fastened in place. All stowage lockers containing heavy items should have lids or doors which are capable of being securely fastened.

#### **21A.17 Protection from mosquitoes**

21A.17.1 Vessels regularly trading to and within mosquito infested ports should be fitted with appropriate devices to minimise the effects on seafarers.

#### **21A.18 Master's inspections**

21A.18.1 There should be weekly documented inspections carried out on board vessels, by or under the authority of the Master, with respect to:

- .1 supplies of food and drinking water;
- .2 all spaces and equipment used for the storage and handling of food and drinking water;
- .3 galley and other equipment used for the preparation and service of meals; and
- .4 that seafarer accommodation is clean, decently habitable and maintained in a good state of repair.

21A.18.2 The results of each inspection should be recorded and made available for review.

**21B**                    **ACCOMMODATION – VESSELS ≥200GT BUILT ON OR AFTER THE [Date of coming into force of MLC 2006]**

Objective: The purpose of this section is to implement substantially equivalent arrangements to the seafarer accommodation requirements of the Maritime Labour Convention 2006 to vessels built after the coming into force of the Convention on the [date of coming into force]. There are alternative arrangements for vessels of traditional design and vessels under 200GT which do not trade internationally. The aim of the Convention is to provide a comprehensive set of global maritime labour standards for all seafarers, including accommodation standards.

**21B.1**                    **Introduction**

21B.1.1                This section applies to vessels, the keel of which was laid or was at a similar stage of construction, on or after the [date of coming into force of the MLC 2006].

21B.1.2                When agreed with the Administration, vessels which are of traditional build and are true replicas of traditionally designed yachts, which includes wooden yachts, 'J Class' yachts and other yachts of similar design where their traditional character is incompatible with the detailed accommodation requirements, particularly with regard to cabin size, are excepted from the requirements of this section and should comply with Section 21.

**21B.2**                    **General**

21B.2.1                Accommodation should provide decent living conditions and recreational facilities for all seafarers onboard the vessel. The accommodation should also be adequate for all persons who are not seafarers onboard the vessel.

21B.2.2                In order to provide decent living conditions and recreational facilities the following requirements are provided as minimum standards.

21B.2.3                The materials used to construct internal bulkheads, panelling and sheeting, floors and joinings should be suitable for the purpose and conducive to ensuring a healthy environment. All relevant health and safety standards should be observed.

21B.2.4                The accommodation should be adequately insulated; proper lighting and sufficient drainage should be provided.

21B.2.5                There should be no direct openings into sleeping rooms from cargo and machinery spaces or from galleys, storerooms, drying rooms or communal sanitary areas. That part of a bulkhead separating such places from sleeping rooms and external bulkheads should be efficiently constructed of steel or other approved material and be watertight and gas-tight. The requirement to be watertight and gas-tight is taken to mean that bulkheads should be so constructed as to prevent ingress of water, cooking smells, and noxious gases into adjacent cabins.

### **21B.3 Headroom**

21B.3.1 There should be adequate headroom in all seafarer accommodation. The minimum permitted headroom in all seafarer accommodation where full and free movement is necessary should be not less than 203 centimetres. Some limited reduction in headroom in any space, or part of any space, in such accommodation may be permitted, provided this is reasonable and does not result in discomfort to the seafarer and is agreed with the Administration.

### **21B.4 Access/Escape arrangements**

21B.4.1 See 14A.3 and 14B.2.12.

### **21B.5 Lighting**

21B.5.1 Seafarer's sleeping rooms and mess rooms should be lit by natural light and provided with adequate artificial light. Where the provision of natural light is impracticable, adequate artificial light may be acceptable in limited areas.

### **21B.6 Heating**

21B.6.1 Adequate heat through an appropriate heating system should be provided, except in vessels exclusively operating in tropical climates.

### **21B.7 Ventilation**

21B.7.1 Sleeping rooms and mess rooms should be adequately ventilated. Vessels, except those regularly operating in areas where temperate climatic conditions do not require this, should be equipped with air conditioning for seafarer accommodation, for any separate radio room and for any centralised machinery control room. All sanitary spaces should have ventilation that draws from the accommodation and extracts to the open air, independently of any other part of the accommodation.

21B.7.2 Mechanical ventilation should be provided to all accommodation spaces on vessels which are intended to make long international voyages or operate in tropical waters. As a minimum, mechanical ventilation should be capable of providing 6 changes of air per hour, when all access and other openings (other than ventilation intakes) to the spaces are closed.

21B.7.3 Air conditioning systems are to provide a minimum of 25 cubic metres of air per hour, per person accommodated in the ventilated space during normal operating conditions.

### **21B.8 Sleeping Accommodation**

21B.8.1 Where practicable the sleeping accommodation should meet the full requirements of the Maritime Labour Convention 2006 provided in 21B.8.2. Where this is not practicable the sleeping accommodation should meet the substantially equivalent requirements of 21B.8.3 for vessels of 200GT and over and less than 500GT, and 21B.8.4 for vessels of 500GT and over and less than 1250GT.

## **21B.8.2 Full Maritime Labour Convention 2006 requirements**

- 21B.8.2.1 Sleeping rooms should be situated above the deepest waterline amidships or aft where practicable. Where this is impractical, sleeping rooms may be located in the fore part of the vessel, but in no case forward of the collision bulkhead nor immediately beneath working alleyways<sup>3</sup>.
- 21B.8.2.2 When it is neither reasonable nor practicable to site seafarer sleeping accommodation amidships or aft, and above the deepest waterline as required, measures taken to ensure an equivalent level of seafarer health and safety should be agreed with the Administration. Where the sole of the sleeping accommodation is below the deepest waterline amidships, a bilge flooding alarm should be provided in the sleeping accommodation to provide early warning of flooding to that compartment. Sleeping accommodation with the deck head lining below the deepest intact waterline is not permitted. In addition, for vessels other than short range yachts, where such accommodation is sited partially below the deepest waterline it should be arranged such that in the event of damage to the watertight compartment in which the accommodation space is situated, the deck head lining should not be immersed. Satisfactory arrangements should be made for lighting and ventilation.
- 21B.8.2.3 Separate sleeping rooms should be provided for men and for women.
- 21B.8.2.4 A separate berth for each seafarer should in all circumstances be provided. The minimum inside dimensions of a berth should be at least 198 centimetres by 80 centimetres. Narrower berths may be permitted in either (a) sleeping rooms occupied by only one seafarer or (b) sleeping rooms where en-suite sanitary facilities are provided, as long as in no case the width at one end is no less than 50 centimetres and the width is at least 80 centimetres at the opposite end over half the length of the bed.
- 21B.8.2.5 Where practical, the master, the chief engineer and the chief navigating officer should have, in addition to their sleeping rooms, an adjoining sitting room, day room or equivalent additional space. The Navigating Bridge, if suitably fitted, may be considered if it is available for this exclusive use when the ship is not engaged in navigation. When the ship is engaged in navigation, the watchkeepers should not be distracted.
- 21B.8.2.6 Every seafarer is to be provided with a clothes locker of ample space (minimum 475 litres) and a drawer or equivalent space of not less than 56 litres. If the drawer is incorporated in the clothes locker then the combined minimum volume of the clothes locker should be 500 litres. The locker should be fitted with a shelf and be able to be locked by the seafarer so as to ensure security and maintain privacy. Where the total required volume cannot be provided within the cabin, the Administration may consider accepting secure facilities for the individual elsewhere within the seafarer accommodation, provided that within the cabin a minimum of 300 litres storage space is provided for each individual seafarer.
- 21B.8.2.7 Sleeping rooms should be provided with a table or desk, which may be of the fixed, drop-leaf or slide-out type or other alternative individual table, and with comfortable seating accommodation as necessary.
- 21B.8.2.8 In calculating the floor area of sleeping rooms, spaces occupied by berths, lockers, seats, chests of drawers and other furniture should be included in the

---

<sup>3</sup> Sleeping rooms should not be subject excessive noise or vibration which may affect the seafarer's ability to rest.

area but spaces which by reason of their small size or irregular shape cannot accommodate furniture and do not contribute to the area available for free movement should not be included. Where a berth or other fixed furniture is situated at the side of the vessel the projected area (to floor level) of such berths or fixed furniture may be used in the calculation of the sleeping room area.

21B.8.2.9 To the extent possible an individual sleeping room should be provided for each seafarer, the floor area of which should not be less than 4.5 square metres. This minimum floor area may include en-suite sanitary facilities where provided.

21B.8.2.10 Where it is not practical to provide single occupancy cabins, sleeping rooms to be occupied by a maximum of two seafarers may be accepted, provided that the floor area of such sleeping rooms is not less than 7 square metres. The floor area may include en suite sanitary facilities, if provided.

21B.8.2.11 The floor area for sleeping rooms for seafarers who are officers on vessels where an adjoining sitting room, day room or equivalent additional space are provided should not be less than 4.5 square metres per seafarer. This area **may** include en-suite sanitary facilities.

21B.8.2.12 The floor area for sleeping rooms for seafarers who are officers on vessels where no adjoining sitting room, day room or equivalent additional space are provided should not be less than 7.5 square metres per seafarer. This area **may** include en-suite sanitary facilities.

**21B.8.3 Equivalent arrangements to the full Maritime Labour Convention 2006 sleeping accommodation for vessels of 200GT and over and less than 500GT.**

21B.8.3.1 Sleeping rooms should be situated above the deepest waterline amidships or aft where practicable. Where this is impractical, sleeping rooms may be located in the fore part of the vessel, but in no case forward of the collision bulkhead nor immediately beneath working alleyways<sup>4</sup>.

21B.8.3.2 When it is neither reasonable nor practicable to site seafarer sleeping accommodation amidships or aft, and above the deepest waterline as required, measures taken to ensure an equivalent level of seafarer health and safety should be agreed with the Administration. Where the sole of the sleeping accommodation is below the deepest waterline amidships, a bilge flooding alarm should be provided in the cabin to provide early warning of flooding to that compartment. Sleeping accommodation with the deck head lining below the deepest intact waterline is not permitted. In addition, for vessels other than short range yachts, where such accommodation is sited partially below the deepest waterline it should be arranged such that in the event of damage to the watertight compartment in which the accommodation space is situated, the deck head lining should not be immersed. Satisfactory arrangements should be made for lighting and ventilation.

21B.8.3.3 Separate sleeping rooms should be provided for men and for women.

21B.8.3.4 A separate berth for each seafarer should in all circumstances be provided. The minimum inside dimensions of a berth should be at least 198 centimetres by 80 centimetres. Narrower berths may be permitted in either (a) sleeping rooms

---

<sup>4</sup> Sleeping rooms should not be subject excessive noise or vibration which may affect the seafarer's ability to rest.

occupied by only one seafarer or (b) sleeping rooms where en-suite sanitary facilities are provided, as long as in no case the width at one end is no less than 50 centimetres and the width is at least 80 centimetres at the opposite end over half the length of the bed.

- 21B.8.3.5 Where practical, the master, the chief engineer and the chief navigating officer should have, in addition to their sleeping rooms, an adjoining sitting room, day room or equivalent additional space. The Navigating Bridge, if suitably fitted, may be considered if it is available for this exclusive use when the ship is not engaged in navigation. When the ship is engaged in navigation, the watchkeepers should not be distracted.
- 21B.8.3.6 Every seafarer is to be provided with a clothes locker of ample space (minimum 475 litres) and a drawer or equivalent space of not less than 56 litres. If the drawer is incorporated in the clothes locker then the combined minimum volume of the clothes locker should be 500 litres. The locker should be fitted with a shelf and be able to be locked by the seafarer so as to ensure security and maintain privacy. Where the total required volume cannot be provided within the cabin, the Administration may consider accepting secure facilities for the individual elsewhere within the seafarer accommodation, provided that within the cabin a minimum of 300 litres storage space is provided for each individual seafarer.
- 21B.8.3.7 Sleeping rooms should be provided with a table or desk, which may be of the fixed, drop-leaf or slide-out type or other alternative individual table, and with comfortable seating accommodation as necessary.
- 21B.8.3.8 Where a single berth seafarer's cabin without en-suite sanitary facilities is provided it should have a floor area of not less than 3.6 square metres.
- 21B.8.3.9 A single berth seafarer's cabin provided with en-suite sanitary facilities, should have a floor area of not less than 4.5 square metres. En-suite sanitary facilities are considered to compensate for reduced floor area and form part of the floor area.
- 21B.8.3.10 Sleeping rooms occupied by two seafarers without en-suite sanitary facilities should have a floor area of not less than 7 square metres.
- 21B.8.3.11 A cabin occupied by two seafarers where en-suite sanitary facilities are provided should have a minimum floor area of 6.2 square metres. En-suite sanitary facilities are considered to compensate for reduced floor area and form part of the floor area.
- 21B.8.3.12 Where the reduced floor areas in 21B.8.3.8 to 21B.8.3.11 are adopted, the free floor area in the sleeping accommodation should be at least 1.45 square metres per seafarer to provide for sufficient comfortable movement.
- 21B.8.3.13 Where the requirement of 21B.8.3.12 is not practical due to the hull shape or hull stiffening, but the arrangements in the cabin allow for a free movement of the upper part of the body equivalent to an area of 1.45 square metres, a reduced free floor area may be provided with the Administration's agreement, but should not be less than 1 square metre per seafarer.
- 21B.8.3.14 Where the requirements of 21B.8.3.13 are accepted by the Administration, the en-suite sanitary facilities should be large enough to allow for the facilities to be used with the door closed and would not be expected to have a floor area of less than 1.2 square metres. Where the floor area of the en-suite sanitary facilities provided is greater than 1.2 square metres, the free floor area of the cabin may

be reduced accordingly, but should never be less than 1 square metre per seafarer.

**21B.8.4 Equivalent arrangements to the full Maritime Labour Convention 2006 sleeping accommodation for vessels of 500GT and over and less than 1250GT.**

21B.8.4.1 Sleeping rooms should be situated above the deepest waterline amidships or aft where practicable. Where this is impractical, sleeping rooms may be located in the fore part of the vessel, but in no case forward of the collision bulkhead nor immediately beneath working alleyways<sup>5</sup>.

21B.8.4.2 When it is neither reasonable nor practicable to site seafarer sleeping accommodation amidships or aft, and above the deepest waterline as required, measures taken to ensure an equivalent level of seafarer health and safety should be agreed with the Administration. Where the sole of the sleeping accommodation is below the deepest waterline amidships, a bilge flooding alarm should be provided in the cabin to provide early warning of flooding to that compartment. Sleeping accommodation with the deck head lining below the deepest intact waterline is not permitted. In addition, for vessels other than short range yachts, where such accommodation is sited partially below the deepest waterline it should be arranged such that in the event of damage to the watertight compartment in which the accommodation space is situated, the deck head lining should not be immersed. Satisfactory arrangements should be made for lighting and ventilation.

21B.8.4.3 Separate sleeping rooms should be provided for men and for women.

21B.8.4.4 A separate berth for each seafarer should in all circumstances be provided. The minimum inside dimensions of a berth should be at least 198 centimetres by 80 centimetres. Narrower berths may be permitted in either (a) sleeping rooms occupied by only one seafarer or (b) sleeping rooms where en-suite sanitary facilities are provided, as long as in no case the width at one end is no less than 50 centimetres and the width is at least 80 centimetres at the opposite end over half the length of the bed.

21B.8.4.5 Where practical, the master, the chief engineer and the chief navigating officer should have, in addition to their sleeping rooms, an adjoining sitting room, day room or equivalent additional space. The Navigating Bridge, if suitably fitted, may be considered if it is available for this exclusive use when the ship is not engaged in navigation. When the ship is engaged in navigation, the watchkeepers should not be distracted.

21B.8.4.6 Every seafarer is to be provided with a clothes locker of ample space (minimum 475 litres) and a drawer or equivalent space of not less than 56 litres. If the drawer is incorporated in the clothes locker then the combined minimum volume of the clothes locker should be 500 litres. The locker should be fitted with a shelf and be able to be locked by the seafarer so as to ensure security and maintain privacy. Where the total required volume cannot be provided within the cabin, the Administration may consider accepting secure facilities for the individual elsewhere within the seafarer accommodation, provided that within the cabin a minimum of 300 litres storage space is provided for each individual seafarer.

---

<sup>5</sup> Sleeping rooms should not be subject excessive noise or vibration which may affect the seafarer's ability to rest.

- 21B.8.4.7 Sleeping rooms should be provided with a table or desk, which may be of the fixed, drop-leaf or slide-out type or other alternative individual table, and with comfortable seating accommodation as necessary.
- 21B.8.4.8 Where a single berth seafarer's cabin without en-suite sanitary facilities is provided it should have a floor area of not less than 3.6 square metres.
- 21B.8.4.9 A single berth seafarer's cabin provided with en-suite sanitary facilities, should have a floor area of not less than 4.5 square metres. En-suite sanitary facilities are considered to compensate for reduced floor area and form part of the floor area.
- 21B.8.4.10 Sleeping rooms occupied by two seafarers without en-suite sanitary facilities should have a floor area of not less than 7 square metres.
- 21B.8.4.11 Single occupancy cabins for seafarers who are officers for whom no adjoining sitting room, day room or equivalent additional space are provided should be not less than 4.5 square metres for a vessel of 500GT and not less than 7.5 square metres for vessels of 1250GT and over. For a vessel of intermediate gross tonnage the floor area should be determined by linear interpolation, as shown in Figure 21B.1 below.

Figure 21B.1 – Cabin Floor Areas – Single Occupancy

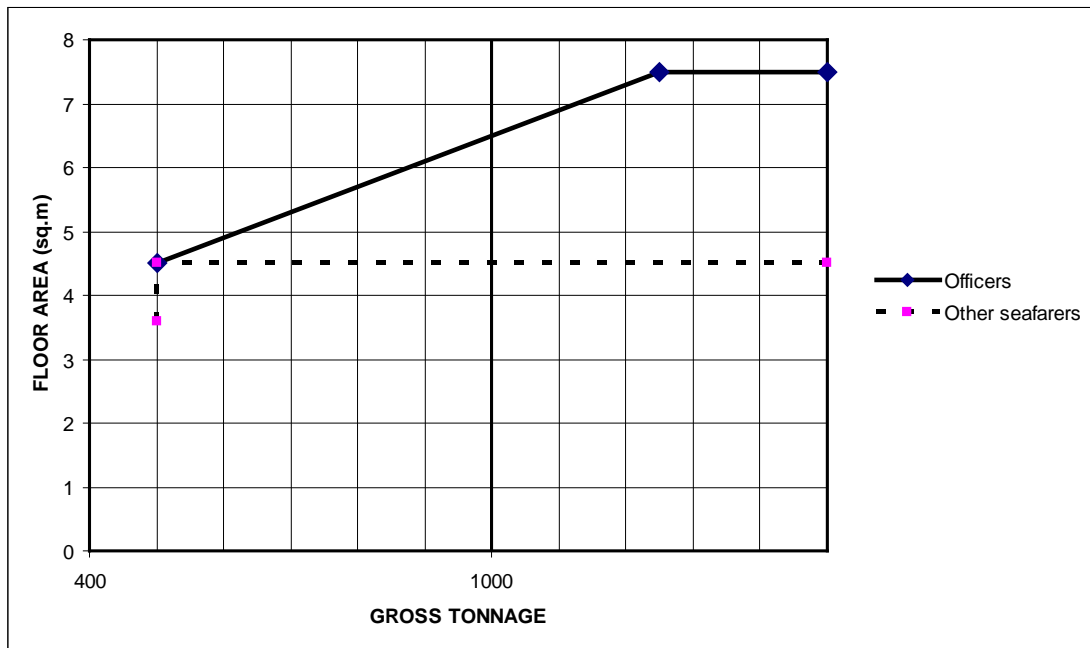

21B.8.4.12 Floor areas of double occupancy cabins with en-suite sanitary facilities for seafarers who are officers should be not less than 6.2 square metres for a vessel of 500GT and not less than 15 square metres for vessels of 1150GT and over. For a vessel of intermediate gross tonnage the floor area should be determined by linear interpolation, as shown in Figure 21B.2 below. For seafarers who are not officers, the floor area of a double occupancy cabin with en-suite sanitary facilities should increase at the same rate as cabins provided for seafarers who are officers until it is 7 square metres.

Figure 21B.2 – Cabin Floor Areas – Double Occupancy

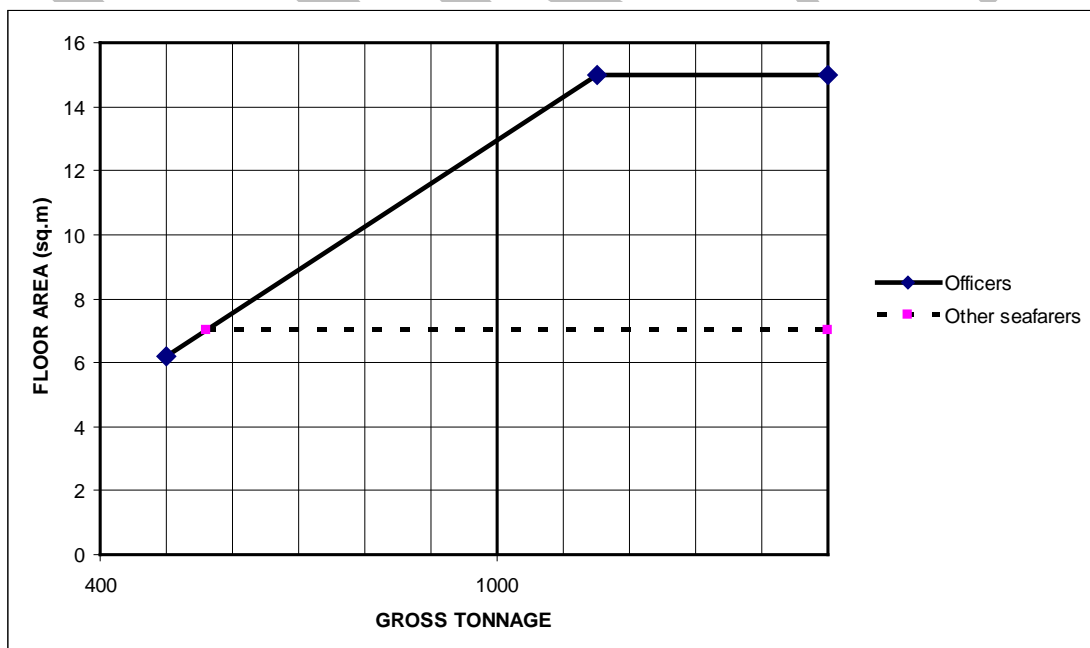

- 21B.8.4.13 Officer's cabins with a floor area less than 7.5 square metres should be provided with televisions and DVD players or equivalent electronic audio-visual equipment.
- 21B.8.4.14 Where sitting rooms are not provided in accordance with 21B.4.11 an additional space providing a comfortable shared sitting area for seafarers who are officers should be provided with a floor area of 1.5 square metres per officer. The wheelhouse, if suitably fitted, may be considered if it is available for this exclusive use when the vessel is not engaged in navigation. When the ship is engaged in navigation, the watchkeepers should not be distracted.

## **21B.9 Mess Rooms**

- 21B.9.1 Mess rooms should be located apart from the sleeping rooms to avoid disturbing those persons sleeping and as close as practicable to the galley. Mess rooms should be of adequate comfort and properly furnished and equipped (including ongoing facilities for refreshment), taking account of the number of seafarers likely to use them at any one time. Mess rooms for seafarers who are officers and other seafarers may be separate or common, as appropriate.
- 21B.9.2 Where the substantially equivalent arrangements in 21B.8.3 and 21B.8.4 are used, the floor area of mess rooms for seafarers should not be less than 1.5 square metres per person of the planned seating capacity.

## **21B.10 Galley Areas, Food Preparation, Storage, and Provision of Food**

- 21B.10.1 Adequate food should be provided for all seafarers onboard free of charge. The provision of food should take account of the seafarers' religious requirements and cultural practices, the nature and duration of the voyage, and should be suitable in respect of quantity, nutritional value, quality and variety.
- 21B.10.2 The organisation and equipment of the catering department should be such as to permit the provision to the seafarers of adequate, varied and nutritious meals prepared and served in hygienic conditions. This should include as a minimum that the galley is fitted with a means of cooking and a sink and have adequate working surface for the preparation of food. The galley floor should be provided with a non-slip surface and provide a good foothold.
- 21B.10.3 All furniture and fittings in the galley should be made of a material which is impervious to dirt and moisture. All metal parts of furniture and fittings should be rust resistant.
- 21B.10.4 The ventilation in the galley should be arranged to ensure that there is an adequate supply of fresh air and for the efficient discharge of fumes into the open air. Air conditioning systems are to provide a minimum of 25 cubic metres of air per hour, per person accommodated in the ventilated space during normal operating conditions. Enclosed galleys are to be specially considered, and where air conditioning is not fitted should have, as a minimum, a mechanical supply of 20 fresh air changes per hour and a mechanical exhaust of 30 changes per hour.
- 21B.10.5 When a cooking appliance is gimballed it should be protected by a crash bar or other means to prevent personal injury. Means should be provided to lock the gimbaling mechanism.
- 21B.10.6 Means should be provided to allow the person cooking to be secured in position, with both hands free for working, when the vessel motions threaten safe working. Secure and hygienic storage for food and garbage should be provided.

## **21B.11 Water Services**

21B.11.1 An adequate supply of fresh drinking water should be provided and piped to convenient positions throughout the accommodation spaces.

21B.11.2 In addition, an emergency reserve supply of drinking water should be carried, sufficient to provide at least 2 litres per person the vessel is certificated to carry. The installation of fresh water making machines and disinfection arrangements are to be to the acceptance of the Administration - for this purpose silver ionisation or chlorination would be considered acceptable.

## **21B.12 Sanitary Facilities**

21B.12.1 A minimum of one toilet, one wash basin and one tub or shower or both for every six seafarers or less who do not have en-suite sanitary facilities should be provided at a convenient location.

21B.12.2 Separate sanitary facilities should be provided for men and for women. In respect of sanitary facilities for men and for women, vessels should be provided with a minimum of 2 sets of sanitary facilities for the first two seafarers onboard plus an additional set of sanitary facilities for every additional 6 seafarers.

21B.12.3 Where a sleeping room is provided with en-suite sanitary facilities those facilities should include a minimum of one toilet, one wash basin and one tub or shower or both.

21B.12.4 Where private or semi-private facilities cannot be provided, all seafarers should have convenient access on the vessel to sanitary facilities meeting minimum standards of health and hygiene and reasonable standards of comfort. Hot and cold running fresh water should be available in all wash places.

21B.12.5 Sanitary facilities within easy access of the wheelhouse, and the machinery space or near the engine room control centre should be provided where practical.

21B.12.6 Every sleeping room should be provided with a washbasin with hot and cold running fresh water, except where such a washbasin is situated in the en-suite sanitary facilities provided.

## **21B.13 Hospital accommodation**

21B.13.1 Vessels carrying 15 or more seafarers and engaged in a voyage of more than three days' duration should provide separate hospital accommodation to be used exclusively for medical purposes. This may be a treatment room that also meets the requirements for hospital accommodation. Hospital accommodation should be designed to facilitate the giving of medical first aid and to help prevent the spread of infectious diseases.

21B.13.2 It is recommended that the arrangement of the entrance, berths, lighting, ventilation, heating and water supply should be designed to ensure comfort and facilitate the treatment of occupants.

21B.13.3 Sanitary facilities should be provided for the exclusive use of the occupants of the hospital accommodation, either as part of the accommodation or in close

proximity thereto. Such sanitary facilities should comprise a minimum of one toilet, one washbasin and one tub (to allow a means bathing for the treatment of burns or hypothermia).

21B.13.4 Short-range yachts and other vessels that remain within 60 miles of the coast are exempt from 21B.13.1. In cases where such vessels are engaged on voyages of more than three days duration, for example on re-positioning trips, a en-suite cabin should be designated exclusively for medical purposes.

#### **21B.14 Laundry Facilities**

21B.14.1 Appropriately situated and furnished laundry facilities should be available.

#### **21B.15 Offices**

21B.15.1 Separate offices or a common office for use by deck and engineer seafarers should be provided where practicable.

#### **21B.16 Other Provisions**

21B.16.1 A space or spaces should be provided on open deck for the recreation of seafarers to which seafarers can have access when off duty should be provided. This should have a total floor area of 1.5 square metres per person for the greatest number of seafarers likely to use the space at any one time.

21B.16.2 Vessels regularly trading to and within mosquito infested ports should be fitted with appropriate devices to reduce the effects of mosquitoes on seafarers. This is to be agreed with the Administration.

21B.16.3 Appropriate seafarers' recreational facilities, amenities and services, as adapted to meet the special needs of seafarers who live and work onboard should be provided.

#### **21B.17 Master's Inspections**

21B.17.1 There should be weekly documented inspections carried out on board vessels, by or under the authority of the Master, with respect to:

- .1 supplies of food and drinking water;
- .2 all spaces and equipment used for the storage and handling of food and drinking water;
- .3 galley and other equipment used for the preparation and service of meals; and
- .4 that seafarer accommodation is clean, decently habitable and maintained in a good state of repair.

The results of each inspection should be recorded and made available for review.

## **21B.18 Hand holds and grab rails**

21B.18.1 There should be sufficient hand holds and grab rails within the accommodation to allow safe movement around the accommodation at all times. Stairways should be specially considered.

## **21B.19 Securing of Heavy Equipment**

21B.19.1 All heavy items of equipment such as ballast, batteries, cooking stove, etc, should be securely fastened in place. All stowage lockers containing heavy items should have lids or doors which are capable of being securely fastened.

## **21B.20 Sailing Vessels**

21B.20.1 The requirements of Chapter 21B apply to sailing vessels in the same way as they do to motor vessels.

21B.20.2 Where the sailing vessel is below 1500GT the variations described in 21B.20.3 and 21B.20.4 may be adopted.

21B.20.3 On a case by case basis where due to the number of seafarers and passengers on a sailing vessel, for example a sail training vessel or a sailing vessel used for racing, it is not possible to meet the equivalent arrangements of 21B.8.3.12 (minimum of 1 square metre free floor area per seafarers), seafarers should have no worse accommodation arrangements than the passengers.

21B.20.4 Where it is not possible to meet the requirements of 21B.8.4.14 due to there not being a wheelhouse, an additional space that provides privacy for the seafarers who are officers, such as a spare cabin, may be provided to the satisfaction of the Administration. Such a space should allow the seafarers who are officers to meet privately, or the seafarers who are officers to meet with other seafarers privately.

## 22 PROTECTION OF PERSONNEL

### 22.1 Deckhouses and Superstructures

The structural strength of any deckhouse or superstructure should comply with the requirements of one of the Classification Societies listed in the National Annex, as appropriate to the vessel and its areas of operation.

### 22.2 Bulwarks and Guardrails

22.2.1 Bulwarks and/or guardrails on all accessible decks should be 1000mm high except that on vessels built to 1959 Load Line Rules these may be 915mm high. Any opening should not exceed 380mm. Where no bulwarks are fitted, or bulwark height is less than 230mm, the lowest opening should not exceed 230mm. They should be supported at intervals not exceeding 2.2 metres. Intermediate courses of rails or wires should be evenly spaced.

22.2.2 Satisfactory means (in the form of guard rails, life lines, gangways or underdeck passages, etc.) shall be provided for the protection of the crew in getting to and from their quarters, the machinery space and all other areas used in the necessary work of the craft.

22.2.3 Where the function of the vessel would be impeded by the provision of bulwarks and/or guard rails complying with 22.2.1, alternative proposals detailed to provide equivalent safety for persons on deck should be submitted to the Administration for approval.

### 22.3 Safe Work Aloft, Overside, and on the Bowsprit of Sailing Vessels

22.3.1 When access to the rig, bowsprit, or overside working is required, provision should be made to enable people to work safely, in accordance with national standards, see National Annex.

22.3.2 The arrangements provided should be based on established safe working practices for the type of vessel. The arrangements may include but not be limited to:

- .1 safety nets below the bowsprit;
- .2 safety grab rails or jackstays (metal or wire) fixed along the bowsprit to act as handholds and strong points for safety harnesses;
- .3 mandatory use of safety harnesses aloft, overside, (refer to MGN 422) and for work on the bowsprit;
- .4 sufficient footropes and horses in wire (or rope) permanently rigged to enable seamen to stand on them whilst working out on the yards or on the bowsprit;
- .5 safety jackstays (metal or wire) fixed along the top of the yards, to provide handholds and act as strong points for safety harnesses;
- .6 means of safely climbing aloft, such as:
  - (i) fixed metal steps or ladders attached to the mast; or
  - (ii) traditional ratlines (rope) or, rattling bars (wood/steel), fixed across the shrouds to form a permanent ladder.

## 22.4 Personal Clothing

It should be the responsibility of an owner/managing agent/skipper to advise that the following requirements for items of personal clothing should be met:

- .1 Each person on board a vessel should have protective clothing appropriate to the prevailing air and sea temperatures.
- .2 Each person on board a vessel should have footwear having non-slip soles, to be worn on board.

## 22.5 Noise

Attention is drawn to the IMO Code on Noise Levels on Board Ships, Resolution A.468(XII), published 1982.

22.5.1 Vessels covered by this Code should meet the recommendations so far as is reasonable and practicable.

22.5.2 The IMO Code on Noise Levels on Board Ships promotes the control of noise within the framework of internationally agreed guidelines, whilst recommending methods of measuring noise at listening posts.

22.5.3 For safe navigation, it is important that sound signals and VHF communications can be heard, at the navigating position in normal operating conditions.

22.5.4 For machinery spaces, workshops and stores which are manned either continuously or for lengthy periods, the recommended limits are 90dB(A) for machinery spaces and 85dB(A) for workshops and stores.

For machinery spaces which are not intended to be continuously manned or are attended for short periods only, the recommended limits are 110dB(A).

The limits have been set from hearing damage risk considerations and the use of suitable ear protectors.

22.5.5 To indicate the need to wear ear protectors, safety signs, signs with symbols and supplementary warning notices should be displayed at all entrances to spaces in which the noise level exceeds 85dB(A). See National Annex.

## 22.6 Lifts

Personnel lift installations shall be appropriately designed and constructed, installed and tested by a competent person.

Designs should be submitted at an early stage of construction to prevent delays to delivery. Recognised international standards such as BS EN 81 should be considered but the following gives a minimum standard that should be provided.

1. Structural fire protection requires lift shaft within an "A" class division as per section 14B.2.6. Where the lift shaft is fitted within a stairway enclosure there is no need for "A" class divisions between the lift and the staircase.

2. Construction and installation for marine use shall be supported by a certificate from either:
  - i) Classification Society, ii) insurer, iii) manufacturer, to include a relevant load test.
3. Lift should comprise an enclosed capsule.
4. A suitable means of escape from the capsule and lift shaft should be provided.
5. Mains and emergency power to be provided, where necessary to comply with item 4.
6. Emergency lighting to be provided.
7. An internal alarm and telephone to be provided.
8. Normal operation should ensure lift only stops at each deck.
9. *“Not to be used in case of fire”* sign to be posted within.

Reference standards include:

BS EN 81 series – Safety rules for the construction and installation of lifts  
BS 5655 series – Lifts and service lifts

**MEDICAL STORES**

A vessel should carry medical stores as required by the Administration.

Medical training requirements for members of the complement of the vessel are given in the Manning Section of the National Annex.

SECRET

## **24 SHORE-SHIP TRANSFER OF PERSONNEL**

### **24.1 Tenders**

24.1.1 When a vessel carries a rigid or inflatable tender, it should be fit for its intended use, regularly inspected by the owner/managing agent, and maintained in a safe condition

24.1.2 Safety equipment should be provided in the tender as appropriate to its intended range and area of operation.

24.1.3 Each tender should be clearly marked with the number of persons (mass 75 kg) that it can safely carry, and the name of the parent vessel.

24.1.4 In the case of petrol-engined tenders, see section 14 for the safety requirements for the carriage of petrol.

### **24.2 Helicopters**

24.2.1 When provision is made for helicopter operations to or from the vessel, the helicopter landing area should be located on an appropriate area of the weather or superstructure deck, or on a purpose built landing area permanently attached to the vessel or structure, providing;

.1 the structural strength of the helicopter landing area is designed and constructed according to Classification Society rules on helicopter landing areas for vessels and a Certificate of Compliance is issued by the relevant Classification Society;

.2 all other considerations such as landing area size, means of access, obstacle protected surfaces (sector clearance zones), lighting, and marking should be in accordance with Annex 6 of this Code with a Helicopter Landing Area Certificate issued by the Aviation Inspection Body;

.3 the requirements for helicopter facilities in SOLAS II-2 are complied with in full;

.4 helicopter operations to / from the vessel are restricted to within the weather, pitch, roll, and heave limits for the vessel as defined where appropriate in the relevant operating rules, and / or in the rotorcraft flight manual (RFM) and / or by the Aviation Inspection Body;

.5 the helicopter landing area is designed for the largest helicopter which it is intended to use; and

.6 the operational procedures for the vessel fully reflect the above.

24.2.2 If it is proposed to provide hangar and/or refuelling facilities for a helicopter whilst it is on board the vessel, prior approval should be sought from the Administration. Such facilities should be arranged in accordance with Annex 6 Section 7 and / or 8 of this Code.

24.2.3 In order to meet the full safe landing area size requirement in Annex 6 of this Code, the out-board edges of the landing area may be engineered to retract or fold to a closed position when the landing area is not in use providing the overall safe landing area, including the retractable or movable sides, when fully deployed, provides the minimum load bearing area specified.

- 24.2.3.1 The minimum safe landing area dynamic load bearing capability should be 2.5 times the Maximum Take-Off Mass (MTOM) of the heaviest helicopter intended to use the landing area. This may only be reduced, subject to agreement from both the Classification Society and Administration.
- 24.2.4 The officer(s) in charge of each helicopter landing area operations team should be in possession of an Offshore Petroleum Industry Training Organisation (OPITO) Approved Offshore Helicopter Landing Officer (HLO) certificate. All other crew assigned duties within the helicopter landing area operations team(s) should be in possession of an OPITO Approved Offshore Emergency Helideck Team Member certificate. Certification from an equivalent course approved by the Administration will also be accepted. All helicopter operations certification should be in date.
- 24.2.5 All crew on board should undergo familiarisation training regarding helicopter operations on board and it is recommended that all crew undertake helicopter crash survivability (“dunker”) training at a recognised OPITO training centre, prior to commencement of duties.
- 24.2.6 Ship to shore and ship to helicopter communications procedures, ship operating procedures, and guidance on helicopter emergencies are outlined in the International Chamber of Shipping Guide to Helicopter / Ship Operations and should be used as part of the operational procedures of the vessel.

#### 24.2.7

### 24.3 Pilot for Vessel

Boarding arrangements provided for pilots should have due regard for SOLAS Chapter V, Regulation 23 and IMO Resolution A.889 (21) "Pilot transfer arrangements", International Maritime Pilots' Association (IMPA) recommendations, or any documents replacing them. Also see National Annex for any national requirements.

### 24.4 Gangways, Passerelles, and Accommodation Ladders

- 24.4.1 A safe means of access is to be provided at all times when in port, either deployed or available for deployment. If the safe means of access is not deployed, there shall be a means provided for communication between those on the quay and those on board.
- 24.4.2 When provided, gangways, passerelles, and accommodation ladders should be manufactured to a recognised national or international standard, and be clearly marked with the manufacturer's name, the model number, the maximum design angle of use and the maximum safe loading (by number of persons and by total weight). Side screens or handrail(s) should be provided on both sides.
- 24.4.3 Where gangways, passerelles or ladders do not comply with national or international standards, a manufacturer's test load certificate should be provided. Alternatively practical tests may be carried out to the satisfaction of the Administration. In all cases the maximum design angle, maximum number of persons, and the maximum total weight should be clearly marked, and are to be used in accordance with the manufacturer's instructions.
- 24.4.4 Accommodation ladders should be provided on a vessel of 120 metres in length and over.

24.4.5 Access equipment and immediate approaches to it should be adequately illuminated.

24.4.6 Reference standards include:

BSMA 78:1978 - Gangways (excluding the maximum overall widths specified in table 2); and

BSMA 89:1980 - Accommodation Ladders.

ISO 7061:1993 - Shipbuilding - Aluminium shore gangways for seagoing vessels

ISO 5488:1979 - Shipbuilding - Accommodation ladders

## **24.5 Submersible craft**

24.5.1 Submersible craft carried on yachts should comply with IMO MSC/Circ.981 and their relevant national regulations, including the following:

24.5.2 They should be constructed and maintained in accordance with the rules of a recognised Classification Society, and be suitable for the intended use.

24.5.3 Supporting equipment is to be surveyed by a Classification Society stating maximum safe working load of the equipment and maximum sea state in which the craft may be launched.

24.5.4 A safety management system which may be separate from any system operated by the parent vessel, including an operations manual, must be in place, and subject to annual audit.

24.5.5 Following satisfactory survey and audit, certification for safety of submersible craft and its support equipment should be issued, and is subject to annual survey.

24.5.6 Maintenance should be carried out by the manufacturer or an organisation or person approved by the administration at intervals specified by the manufacturer.

24.5.7 Operating crew to have adequate theoretical and practical training for the type of submersible craft onboard, and have demonstrated ability to operate it.

## 25 CLEAN SEAS

- 25.1 Vessels should comply with all the requirements of MARPOL as prescribed by the regulations of the Administration. For vessels under 400GT it is the owner's responsibility to comply with local administration/port state requirements and for dealing with oily bilge water retention etc.
- 25.2 Every ship of 400GT and above, and every ship which is certified to carry 15 persons or more, should carry a garbage management plan which should include the written procedures agreed for collection, storage, processing and disposal of garbage; and a garbage record book recording disposal and incineration, as outlined in regulation 9 of Annex V of MARPOL.
- 25.3 Special local requirements may exist in national sea areas, ports and harbours. The attention of owners/operators is drawn to the need to comply with local requirements as appropriate.
- 25.4 All yachts should comply with the hull Anti-Fouling System Convention requirements, details of which can be found in MGN 398 and MIN 394.

## 26 MANNING and PERSONNEL CERTIFICATION

### 26.1 HOURS OF WORK

#### 26.1.1 Principles of Safe Manning

IMO Resolution A.890(21) adopted on the 25th November 1999 defines the principles of Safe Manning to ensure the safe operation of, and prevention of pollution from, ships to which the Convention applies. Convention 180 of the International Labour Organisation (ILO) (Seafarer's hours of work and the manning of ships) came into force on the 10th January 2003 and applies to all commercially operated vessels.

The underlying principles of safe manning are considered to extend to Large Yachts within the context of the Code. In this respect an Administration may choose to adopt these arrangements in full, or modify these arrangements to meet particular operational circumstances.

All sea going commercially operated yachts and sail training vessels of more than 24 metres Load Line Length should carry an appropriate number of qualified Deck and Engineer Officers together with a sufficient number of qualified Yacht Ratings to ensure a degree of safety at least equivalent to that established by the IMO guidelines.

#### 26.1.2 Application and Definitions

These guidelines apply to all *"seafarers employed or engaged in any capacity on board every commercially operated large yacht"*.

The term "seafarer", is defined as a person employed or engaged in any capacity on the vessel and should be taken to mean any person employed either directly by a owner/operator or through a manning agency, whose usual place of work is on the vessel and includes the master, officers, crew members, and catering, salon and hotel staff.

#### 26.1.3 Responsibility

Fatigue at sea is a serious safety issue and owners and operators should ensure that all vessels are sufficiently manned to avoid the need to work excessive hours. The owner/operator and the Master are responsible for ensuring, so far as is reasonably practicable, that the Master and all the crew members are properly rested when they begin work and can obtain adequate rest when not on duty.

The owner/operator should ensure that the necessary resources are available to man the vessel so that the limits on hours can be observed. The master is responsible for ensuring compliance with the requirements.

It is also the responsibility of all seafarers to ensure that they are properly rested when they begin duty on the vessel and that they obtain adequate rest when not on duty.

#### 26.1.4 Definition of Hours of Work

Hours of work is defined as when a seafarer is at their employers' disposal and carrying out their duties or activities.

### **26.1.5 On-Call Time**

Where a seafarer's normal period of rest on board a vessel is disturbed by a callout he/she should have adequate compensatory rest.

### **26.1.6 Minimum Hours of Rest**

The owner/operator or Master should ensure that the crew are provided with at least the minimum hours of rest. These should not be less than:

- a) ten hours in any 24-hour period; and b)
- 77 hours in any seven-day period.

Hours of rest may be divided into no more than 2 periods; one of which should be at least 6 hours long, and the interval in between should not exceed 14 hours.

It is expected that as far as practicable the Master will arrange for conducting emergency drills such as musters, fire-fighting and abandon vessel drills in a way which minimises the disturbance to rest periods and provide compensatory rest for seafarers whose normal rest is disturbed by call-outs for drills.

### **26.1.7 Exceptions to the Limits on Hours of Rest**

The limits defined should as far as practicable be observed. However, an exception maybe considered so long as they are agreed between the Master and crew members, and provided that their health and safety, and the safety of the vessel, is not compromised.

When considering whether an exception is appropriate, the Master should give due regard to the associated duties being considered and in this respect exceptions to persons undertaking watch keeping duties and/or with safety critical duties would not be considered appropriate.

In allowing any such agreed exception and to ensure that a crew member does not become fatigued, such exceptions shall be documented and accompanied by commensurate rest arrangements.

### **26.1.8 Schedule of Duties**

The Master should ensure that a schedule of duties is drawn up setting out the hours of work and rest periods for each of the crew. It is recommended that the table or schedule should be in a similar format to that detailed in Annex A of MSN 1767, and show:

- the schedule of duties at sea and duties in port; and
- the minimum hours of rest as defined by the guidelines.

In devising the schedule, operators should take account of factors such as:

- a) nature of the operation;
- b) type and size of vessel;
- c) construction and technical equipment of the vessel;
- d) manning levels and changes in crew numbers due to crew changes and sickness;
- e) the maximum period of continuous watchkeeping;
- f) minimum rest periods;

- g) total workload;
- h) compliance with the ISPS Code as applicable;
- i) the seriousness of irregular working hours and their contribution to causing fatigue and the importance of scheduling reasonably stable working hours.

Changes should not be made to the schedule of duties unless they can be justified by substantially altered work patterns or other significant factors.

Where it is known that a vessel engages in an irregular pattern or that working hours are unlikely to be uniform, this can be taken into account when considering the schedule.

It is not necessary to draw up a new schedule of duties for each voyage, so long as it is applicable to the voyage in question and the composition of the crew for whom it was originally intended has not changed.

A copy of the schedule should be made available to all members of the crew.

## **26.1.9 Exceptions for Emergencies**

Situations may arise in which a seafarer may be required to work during scheduled hours of rest. These include emergencies which threaten the safety of the vessel or put life at risk. In these circumstances, the limits may be exceeded provided compensatory arrangements are subsequently made to avoid fatigue.

## **26.1.10 Records**

The master or authorised person is responsible for ensuring that records of hours of rest are maintained for each of the crew serving on the vessel. The records should be completed monthly in arrears. Each record should be endorsed by the master or authorised person and the seafarer. A copy should be retained by the seafarer.

In an emergency, or when unforeseen events occur, changes may be unavoidable. In these cases records should reflect all deviations from the schedule.

All records should be kept for a minimum of 12 months and should be available for inspection by the flag administration surveyors at any time. Checking the vessel's records may be carried out by the flag administration as part of the normal routine of vessel inspection and will include a check that the appropriate schedules are available and records maintained.

## **26.2 SAFE MANNING**

### **26.2.1 Introduction**

An Administration should ensure that all vessels are safely and sufficiently manned in relation to the nature of their operation with the responsibilities placed on companies owning or operating seagoing vessels, to ensure that their vessels are manned with personnel of appropriate grades who have been properly trained and certificated.

The numbers of certificated officers and certificated and non-certificated ratings,

must be sufficient to ensure safe and efficient operation of the vessel at all times.

The guidelines place a duty on the owner or operator to provide the master of a vessel with the necessary resources to comply with the manning requirements.

### **26.2.2 Responsibilities of Owners and Operators: General Principles**

In fulfilling their responsibility to ensure that vessels are safely and sufficiently manned, owners and operators should:

- .1 make an assessment of the tasks, duties and responsibilities of the vessel's complement required for its safe operation, for the protection of the marine environment and dealing with emergency situations;
- .2 assess the numbers and grades/capacities in the vessel's complement required for the safe operation and for the protection of the environment, and for dealing with emergency situations, including the evacuation of passengers where applicable;
- .3 ensure that the manning level is adequate at all times and in all respects, including meeting peak workloads;
- .4 in case of changes in the nature of the operation, operational area, construction, machinery, equipment or maintenance of the vessel, which may affect the manning level, review the manning level.

In conjunction with these factors the owner or operator should:

- .5 identify all the functions to be undertaken on board during a representative voyage or operational period, including determination of the number of crew required to undertake the relevant tasks and duties under both peak and routine work load conditions;
- .6 identify those functions that constitute a normal operation and determine the numbers of crew required to undertake the concurrent tasks and duties safely;
- .7 identify the skills and experience required to perform those functions;
- .8 establish working arrangements to ensure that the master and crew are capable of undertaking concurrent and continuing operations at the appropriate level(s) of responsibility, as specified, with respect to their skills and training; and
- .9 ensure that the working arrangements allow for sufficient rest periods to avoid fatigue.

### **26.2.3 Establishing Safe Manning Requirements**

Specific factors to be taken into account in determining the safe manning level may include:

- .1 frequency of port calls, length and nature of the voyage;
- .2 operating area(s), waters and type of operations in which the vessel is involved and any special requirements of the operation;
- .3 number, size (kW) and type of main propulsion units and auxiliaries;
- .4 size, type of vessel, equipment and layout;

- .5 construction and technical equipment of vessel;
- .6 method of maintenance;
- .7 how the proposed complement will deal with various emergency situations that may arise;
- .8 navigational duties and responsibilities as required by STCW 95 including the following to:
  - .1 plan and conduct safe navigation;
  - .2 maintain a safe navigational watch;
  - .3 manoeuvre and handle the vessel in all conditions and during all operations;
  - .4 safely moor and unmoor the vessel; and.
  - .5 maintain safety whilst in port.
- .9 Vessel specific operations:
  - .1 the nature and duration of the operation(s) the vessel undertakes and local environmental conditions.
- .10 Vessel operations and care for persons onboard, and maintaining life-saving, fire-fighting and other safety systems in operational condition.
  - .1 maintain the safety and security of all persons on board and keep life saving, fire fighting and other safety systems in operational condition, including the ability to muster and disembark passengers and nonessential personnel;
  - .2 operate and maintain watertight closing arrangements;
  - .3 perform operations necessary to protect the marine environment;
  - .4 provide medical care on board;
  - .5 undertake administrative tasks required for the safe operation of the vessel; and
  - .6 participation in mandatory safety drills and exercises.
- .11 Marine engineering tasks and duties:
  - .1 operate and monitor the vessel's main propulsion and auxiliary machinery;
  - .2 maintain a safe engineering watch;
  - .3 manage and perform fuel and ballast operations; and
  - .4 maintain vessel's engine equipment, system and services.
- .12 Electrical, electronic and control engineering duties:
  - .1 operate vessel's electrical and electronic equipment; and
  - .2 maintain vessel's electric and electronic systems.
- .13 Radio communications:
  - .1 transmit and receive information using vessel communication equipment;
  - .2 maintain a safe radio watch;
  - .3 provide communications in emergencies.
- .14 Maintenance and repair:

- .1 carry out maintenance and repair work to the vessel and its machinery, equipment and systems, as appropriate to the method of maintenance and the repair system used.

.15 Fulfil obligations and requirements of the ISPS Code as applicable.

#### **26.2.4 Guidance on Appropriate Manning Levels**

In determining what constitutes a minimum safe manning level, useful guidance may also be obtained by use of risk and hazard management tools such as formal safety assessment. The minimum safe manning levels should be those required for all reasonably foreseeable circumstances and working conditions to permit the safe operation of the vessel under normal operational conditions.

The tables in Sections 26.2.8 and 26.2.9 provide guidance on the numbers of certificated deck and engineer officers, and ratings that may be considered appropriate to different sizes of vessels and tonnages, **due consideration should also be given to the number of hotel staff required.**

#### **26.2.5 Safe Manning Document**

SOLAS requires that vessels over 500GT, excluding pleasure yachts not engaged in trade, carry a Safe Manning Document. Owners and operators of vessels below 500GT, or those above 500GT solely engaged for pleasure, may also choose to hold a Safe Manning Document in accordance with the tables at Section 26.2.8 and 26.2.9. This will allow the owner to consider a 'range and risk' approach when determining manning levels.

#### **26.2.6 Application for a Safe Manning Document**

Any application for a Safe Manning Document should be made by the owner, or a person authorised to act on their behalf, to the flag Administration of the vessel and include a clear and concise explanation of how:

- .1 the proposed manning level has been determined;
- .2 it takes account of the guidance; and
- .3 it takes account of the hours of work provisions.

A proposal should only be approved and Safe Manning Document issued provided the manning level fully satisfies these principles, recommendations and guidelines.

When the manning level has been agreed, a Safe Manning Document should be issued for that vessel in a format which complies with the requirements of SOLAS, as amended. It should be retained on board and be available for inspection by an authorised person, whenever required.

In the event of any change in equipment, construction or use of the vessel, which may affect the safe manning level, the owner or operator should make an application for the issue of a new Safe Manning Document.

A Safe Manning Document of a vessel may be withdrawn if an owner or operator fails to submit a new proposal where a vessel changes trading area(s), construction, machinery or equipment, or operation and/or method of maintenance have changed, or a vessel persistently fails to comply with the rest hours requirements.

## 26.2.7 Indicative Manning Levels

The owner/operators or managing agent of all seagoing yachts of more than 24 metres Load Line length must ensure that personnel required for the safe operation of the vessel have recent and relevant experience of the type and size of vessel, and the type of operation in which it is engaged.

This section includes indicative manning levels for vessels of 24 metres or more in Load Line length. The owner/operators of vessels of vessels below 500GT or those above 500GT solely engaged for pleasure may find it advantageous to hold a Safe Manning Document.

In addition to the tables specific submissions may be considered from owners and operators of vessels, including those less than 500GT, seeking a varied Safe Manning Document based on a range and risk approach to safe manning with the flexibility to reduce the manning level taking into account, for example a limiting operating area(s) or parameters, and levels of automation.

## 26.2.8 MANNING SCALE FOR MOTOR YACHTS

For details of certificates accepted by the Administration, see National Annex.

Miles from a Safehaven	Personnel	Vessel Type		
		>24m <200GT	200-500GT	500-3000GT
Up to 60	Master	1	1	1
	Chief Officer	1	1	1
	OOW (Nav)	-	-	-
	Chief Engineer	1	1	1
	Second Engineer	-	-	-
	Assistant Engineer	-	1	1
	Yacht Rating	1	2	2
Up to 150	Master	1	1	1
	Chief Officer	1	1	1
	OOW (Nav)	-	-	-
	Chief Engineer	1	1	1
	Second Engineer	-	-	1
	Assistant Engineer	-	1	-
	Yacht Rating	1	2	2
Unlimited	Master	1	1	1
	Chief Officer	1	1	1
	OOW (Nav)	-	1	1
	Chief Engineer	1	1	1
	Second Engineer	-	1	1
	Assistant Engineer	1	-	-
	Yacht Rating	2	2	2

## 26.2.9 MANNING SCALE FOR SAILING YACHTS

For details of certificates accepted by the Administration, see National Annex

Miles from a Safehaven	Personnel	Vessel Type		
		>24m <200GT	200-500GT	500-3000GT
Up to 60	Master	1	1	1
	Chief Officer	1	1	1
	OOW (Nav)	-	-	-
	Chief Engineer	1	1	1
	Second Engineer	-	-	-
	Assistant Engineer	-	1	1
	Yacht Rating	2	2	3
Up to 150	Master	1	1	1
	Chief Officer	1	1	1
	OOW (Nav)	-	-	-
	Chief Engineer	1	1	1
	Second Engineer	-	-	1
	Assistant Engineer	-	1	-
	Yacht Rating	2	2	3
Unlimited	Master	1	1	1
	Chief Officer	1	1	1
	OOW (Nav)	-	1	1
	Chief Engineer	1	1	1
	Second Engineer	-	-	1
	Assistant Engineer	1	1	-
	Yacht Rating	2	2	3

### 26.2.10 Dual Certification

Where appropriate, dual deck and engineer roles may be considered, provided that the officer is suitably qualified in both disciplines and that the person holding the dual role is a person other than the master.

In considering whether a dual role position is appropriate, regard should be had to the overall safe manning level of the vessel. In such cases additional rating(s) may be required to be carried.

### 26.2.11 Sailing Vessels

Depending on the type of rig and level of automation, additional personnel may be required to operate the rig of a sailing vessel.

### 26.2.12 Personal Water Craft

The operators and operation of personal watercraft should comply with the applicable legislation of the state in whose waters they are being operated.

**PASSENGERS**

No vessel to which the Code applies should carry more than 12 passengers on a voyage or excursion. The following meanings apply:

"Passenger" means any person carried in a ship except:

- (a) a person employed or engaged in any capacity on board the ship on the business of the ship;
- (b) a person on board the ship either in pursuance of the obligation laid upon the master to carry shipwrecked, distressed or other persons, or by reason of any circumstances that neither the master nor the owner nor the charterer (if any) could have prevented; and
- (c) a child under one year of age; and

"a person employed or engaged in any capacity on board the vessel on the business of the vessel" may reasonably include:

- .1 bona-fide members of the crew over the minimum school leaving age (about 16years) who are properly employed on the operation of the vessel;
- .2 person(s) employed either by the owner or the charterer in connection with business interests and providing a service available to all passengers; and
- .3 person(s) employed either by the owner or the charterer in relation to social activities on board and providing a service available to all passengers.

With reference to .2 and .3 above, such persons should be included in the crew list required for the vessel, should have received on board familiarisation training as required by STCW, and should not be assigned duties on the muster list.

## 28 SURVEY, CERTIFICATION, INSPECTION AND MAINTENANCE

### 28.1 General

28.1.1 All vessels covered by this code are required to be surveyed and certificated in accordance with the International Load Line Convention; vessels over 400GT under the MARPOL Convention. Vessels over 500GT are required to be surveyed and certificated under the construction and safety equipment requirements of the SOLAS Convention. All vessels of over 300GT are also required to be surveyed and certificated under the radio requirements of SOLAS. Annex 4 is the list of certificates to be issued.

28.1.2 Statutory work may be undertaken by surveyors of the Administration or by surveyors of a Classification Society appointed by the Administration and, for safety radio, an appropriate Certifying Authority in relation to radio installations. See National Annex for delegations.

28.1.3 A vessel to which the International Conventions apply must be surveyed and, if the necessary standards are met, Convention certificates will be issued. All requests for survey and certification must be made to the Administration, the appropriate Classification Society or appropriate Certifying Authority in relation to radio installations. See National Annex for delegations.

### 28.2 Initial Survey (including new-building commercial vessels)

Vessels are required to be issued with the following certificates, as appropriate.

- .1 International Load Line Certificate (all vessels)
- .2 Certificate of Compliance (all vessels) – this certificate is to cover all aspects of the Code for which a separate certificate is not required
- .3 Cargo Ship Safety Construction Certificate (vessels of 500GT and over)
- .4 Cargo Ship Safety Equipment Certificate (vessels of 500GT and over)
- .5 Cargo Ship Safety Radio Certificate (vessels of 300GT and over)
- .6 International Oil Pollution Prevention Certificate (vessels of 400GT and over)
- .7 International Tonnage Certificate (all vessels)
- .8 Safe Manning Document (vessels of 500GT and over)
- .9 Safety Management Certificate (SMC) (vessels of 500GT and over).
- .10 International Ship Security Certificate (ISSC) (vessels of 500GT and over).
- .11 International Sewage Pollution Prevention Certificate (vessels of 400GT and over, or carrying more than 15 persons).
- .12 International Air Pollution Prevention Certificate (vessels of 400GT and over, or having an engine power output greater than 130kw) and/or Engine International Air Pollution Prevention Certificate (for engines having power output greater than 130kw).

13. Antifouling System Certificate of Compliance (vessels of 400GT and over) (vessels less than 400GT require a declaration on AFS).

### **28.3 Equivalents to certain safety regulations**

If an owner/managing agent seeks any equivalence to the application of specific regulations or requirements, formal application must be made to the Administration, demonstrating an equivalent level of safety. The Administration will issue an equivalent, if and when appropriate.

### **28.4 Periodical Surveys**

#### **28.4.1 Load Line Certificates, Cargo Ship Safety Construction Certificates and Certificates of Compliance (valid for 5 years in general)**

Annual, intermediate and renewal surveys with respect to the Load Line Certificates, the Cargo Ship Safety Construction Certificates and the Certificate of Compliance should be carried out to the satisfaction of the Administration or Class Society as appropriate.

Any certificate is to be valid for not more the 5 years from the date of survey.

#### **28.4.2 Cargo Ship Safety Equipment and Safety Radio Certificates**

28.4.2.1 Safety Equipment Certificates and Safety Radio Certificate surveys should be carried out either by the Administration or Parties to the SOLAS Convention at the request of a the Administration; or by a Classification Society surveyor appointed by the Administration to act on its behalf; or by an appropriate Certifying Authority in relation to radio installations for cargo ships.

28.4.2.2 An application to the Administration for an extension to the certificate will be agreed only in cases when it appears proper and reasonable to do so.

28.4.2.3 At least once during a five year period, a surveyor appointed by the Administration will visit the ship to survey its safety equipment and to conduct a general inspection to ensure that standards are being met.

### **28.5 Use of an Authorised Classification Society**

An authorised Classification Society is aware of the extent to which responsibility has been delegated to issue Load Line Certificates and Cargo Ship Safety Construction Certificates. International Conventions give specific discretion to an Administration to either make exemptions or accept equivalent equipment or arrangements. The formal agreement between the Administration and an authorised Classification Society governs the relationship between the two parties.

### **28.6 Use of a Classification Society Surveyor to act on the behalf of the Administration**

An exclusive surveyor from an authorised Classification Society and proposed by the Society may be appointed from time to time to act on behalf of the Administration in cases when it is impracticable for a surveyor of the Administration to make the visit necessary for the survey.

When a Classification Society surveyor is so appointed, actions taken will be under direct instruction of the Administration. The Administration will provide the appointed surveyor with detailed guidance on the scope of survey and report required.

## **28.7 Accident Investigations**

The Administration with which the vessel is registered is obliged to investigate accidents or incidents in accordance with the requirements of International Conventions. Apart from this legal requirement, an Administration investigates such occurrences to demonstrate the effective control and importance they attach to safety at sea.

It is an offence for the vessel's master, skipper or owner not to inform the appropriate authority of a reportable accident shortly after it occurs and to provide details so that an assessment of its seriousness can be made quickly. The marine Administration will appoint a suitable surveyor or inspector whenever an investigation is required. The Marine Administration will then receive the Surveyor's or the Inspector's report and will deal with the follow up action.

All serious casualties in accordance with the International Maritime Organization's (IMO) definition should be reported to IMO through the Administration.

**29 Crew Agreements**

29.1 Crew Agreements should be available on board as required by the Administration.

**29A** *Section 29 may be amended by the introduction of the International Labour Organisation's (ILO) requirements under the Maritime Labour Convention (MLC) 2006.*

SECRET

**30 SAFETY MANAGEMENT**

30.1 All vessels of 500GT and over, and associated managers, are required to comply with the IMO's International Safety Management Code

30.2 All vessels under 500GT should employ a safety management system as described in Annex 2.

30.3 All vessels to include emergency towing procedures, as required by SOLAS regulation II-1/3-4, in their safety management system.

DRAFT

**INTERNATIONAL SHIP AND PORT FACILITY CODE**

All vessels of 500GT and over are required to comply with the **IMO's International Ship and Port Facility Security Code.**

DRIVER

## **ANNEX 1 MEMBER'S OF THE STEERING COMMITTEE AND WORKING GROUP RESPONSIBLE FOR THE CODE**

### **Steering Committee**

British Marine Federation  
Cayman Islands Shipping Registry  
Maritime and Coastguard Agency  
Professional Yachtsmen's Association  
Royal Yachting Association

### **Working Group**

Alloy Yachts International Ltd  
Amels Holland b.v.  
American Bureau of Shipping  
British Marine Federation  
Cayman Islands Shipping Registry  
De Voogt Naval Architects  
Dubois Naval Architects Ltd  
Feadship Holland  
Fraser Yachts  
Isle of Man Shipping Registry  
**Lloyd's Register**  
Marine Design (New Zealand)  
Maritime and Coastguard Agency  
Mediterranean Yacht Brokers Association  
Nigel Burgess Ltd  
Perini Navi  
Professional Yachtsmen's Association  
Registro Italiano Navale  
Ron Holland Design  
Royal Yachting Association  
Sunseeker International  
Superyacht Society  
SYBASS  
Unione Nazionale Cantieri e Industrie Nautiche ed Affini  
Wright Maritime Group

## ANNEX 2 SAFETY MANAGEMENT SYSTEM FOR VESSELS UNDER 500GT

### INTRODUCTION

1. The purpose of this Annex is to provide guidance on how to develop and implement an effective safety management system for vessels under 500GT, where full certification to the International Safety Management Code is not a requirement.

### GENERAL

2. Each operator should create a safe working environment, which should include the following:

#### **A health and safety protection policy.**

- 2.1 This must address the issues of health, safety and the environment as they affect the company and its staff, both ashore and afloat. Such a policy might read along the following lines:

*"The policy of (name of Company/Owner) is to conduct its activities taking full account of the health and safety of its employees and of all persons using or connected with the Company/Owner. In implementing this policy, (name of Company/Owner) will ensure that the [vessel] is, at all times, properly maintained and operated by qualified personnel in full compliance with relevant legislation. In particular the [Company/Owner] will carry out an assessment of the risks to the health and safety of workers and others affected by [the undertaking], and will take the necessary measures to minimise the risks identified."*

- 2.2 The owner/operator is recommended to develop and implement an oil management plan to the same standard as the garbage management plan and to integrate it with the Health and Safety Protection Policy. This is not required for vessels over 400GT, for which an IOPP certificate is required.

#### **Procedures to ensure safe operation of vessels in compliance with the regulations and rules.**

- 2.3 The regulations and rules, not addressed by this Code of Practice, which apply to all vessels include, but are not limited to:

- International Regulations for Preventing Collisions at Sea;
- Local Navigation Rules;
- National health and safety regulations;
- The Code of Safe Working Practices for Merchant Seamen;
- All relevant national shipping or guidance notices.

- 2.3.1 The company should draw up simple procedures to ensure that safe working practices are carried out in the operation of the vessel. These may be in the form of checklists which can be followed by all personnel.

- 2.3.2 For some vessels, it might be appropriate to have permanently exhibited checklists, e.g. in the wheelhouse for navigational items. Alternatively, in a smaller vessel, the record could take any suitable form such as a diary as distinct from a specially printed logbook. Whatever form the record takes, such entries should be accepted as evidence of compliance with the ONBOARD PROCEDURES requirements.

### **Lines of communication between personnel, ashore and afloat.**

- 2.4 Responsibility and authority of each employee should be clear. This may be best illustrated in a simple diagram, showing who reports to whom.

### **Procedures for reporting accidents.**

- 2.5 The requirement for reporting accidents should be well understood by all personnel and in so doing improve the safety culture practiced on board.

### **Procedures for responding to emergency situations.**

- 2.6 There should be clearly stated procedures for responding to emergency situations. These may include but not be limited to:

- fire
- collision
- grounding
- violent act
- main propulsion or steering failure
- man overboard

- 2.6.1 Checklists may be useful in this regard.

## **HEALTH AND SAFETY PROTECTION POLICY**

3. One or more competent persons should be delegated to take responsibility for health and safety, and that person/persons should be clearly identified. It is the responsibility of the owner/operator to ensure that the policy is complied with, and that the responsibilities are understood.

0

4. The company/owner should develop a policy on prevention of alcohol and drug abuse.

1

5. All personnel both ashore and afloat have a duty to take care of themselves and other persons who may be affected by their acts or omissions.

2

6. It is essential that, in the event of an emergency, there is the ability to communicate with the emergency services via a shore base. The shore base may be the company office ashore, the local Coastguard, Police or Fire Station, or another office as may be agreed between the vessel and the shore base.

## **RESPONSIBILITIES**

7. The Master must have authority at all times, to make decisions with regard to the safety of the vessel and the persons on board. To ensure that there is no ambiguity regarding the authority of the Master, there should be a simple written statement to this effect.

## **PERSONNEL AND TRAINING**

8. All personnel should receive training appropriate to the tasks they undertake. It is the responsibility of the company/owner to ensure that this training is given, and that the personnel have an understanding of the relevant regulations and rules.

9. As a minimum, this means:
- for the Master, the relevant qualifications;
  - for the crew, relevant qualifications and any additional training appropriate to their designated duties.

10. Prior to the first occasion of working on the vessel, each employee must receive appropriate familiarisation training and proper instruction in onboard procedures. This could include, but not necessarily be, limited to:

- mooring and unmooring;
- launching and recovery of survival craft;
- evacuation from all areas of the vessel;
- donning of lifejackets; and
- use and handling of fire fighting equipment.

#### **ONBOARD PROCEDURES**

11. Simple procedures should be developed for the operation of the vessel. These should include, but not be limited to:

- testing of equipment, including steering gear, prior to commencing a passage;
- navigation and handling of the vessel;
- maintenance routines;
- bunkering operations;
- watertight/weathertight integrity;
- stability of the vessel;
- conduct of passengers and crew while on board;
- **emergency towing;**
- **safe use and qualification of users for personal watercraft.**

#### **PREPARATION FOR EMERGENCIES**

12. The potential emergencies likely to be encountered by the vessel should be considered. Exercises should then be carried out in the handling of these emergencies and evacuation from the vessel.

13. Where possible, all personnel should be involved in these exercises, both ashore and afloat.

14. The roles and responsibilities of all personnel in an emergency situation should be defined.

15. The exercises should be recorded. The names of those who participated should also be recorded.

#### **REPORTING OF ACCIDENTS**

16. Vessels operating under this Code are required to report any accidents to the Administration and the company must therefore have a procedure in place. Additionally, all accidents and near accidents should be recorded and reported to the operator/owner, who should implement corrective action, with the aim of improving safety.

## **MAINTENANCE OF THE VESSEL AND EQUIPMENT**

17. Maintenance of the vessel and equipment is an essential ingredient of safety management. The equipment should be checked and tested daily when in use, in addition to the tests referred to in the ONBOARD PROCEDURES section of the Code.
18. There should be procedures for a more detailed inspection and maintenance programme of the vessel and equipment.
19. The frequency of the inspections should be determined by the owner/operator, but every event should be recorded.
20. A checklist could be employed as an aide memoir for the inspection of equipment.

## **REVIEW**

21. Every company/owner should undertake a review of the safety management system of all vessels at least once in every three years.

## **ANNEX 3 OPEN FLAME GAS INSTALLATIONS**

### **1 General Information**

- 1.1 Possible dangers arising from the use of liquid petroleum gas (LPG) open flame appliances in the marine environment include fire, explosion and asphyxiation, due to leakage of gas from the installation.
- 1.2 Consequently, the siting of gas-consuming appliances and storage containers and the provision of adequate ventilation to spaces containing them, is most important.
- 1.3 It is dangerous to sleep in spaces where gas-consuming open flame appliances are left burning, because of the risk of carbon monoxide poisoning.
- 1.4 LPG is heavier than air and if released, may travel some distance whilst seeking the lowest part of a space. Therefore, it is possible for gas to accumulate in relatively inaccessible areas, such as bilges, and diffuse to form an explosive mixture with air, as in the case of petrol vapour.
- 1.5 A frequent cause of accidents involving LPG installations is the use of unsuitable fittings and improvised "temporary" repairs.

### **2 Stowage of Gas Containers**

- 2.1 LPG cylinders, regulators and safety devices should be stowed on the open deck (where leakage will not accumulate) or in a compartment that is vapour-tight to the vessels interior, and fitted with a vent and drain, so that any gas which may leak can disperse overboard.
- 2.2 The vent and drain should not be less 19mm in diameter, run to the outside of the craft and terminate 75mm or more above the "at rest" waterline. Generally, the drain and locker ventilation should be 500 mm or more from any opening to the interior.
- 2.3 The cylinders and associated fittings should be positively secured against movement and protected from damage in any foreseeable event.
- 2.4 Any electrical equipment located in cylinder lockers should be certified safe for use in the potential explosive atmosphere.

### **3 Cylinders and Attachments**

- 3.1 Each system shall be fitted with a readily accessible, manually operated isolating valve in the supply pressure part of the system.
- 3.2 In multiple container installations, a non-return valve should be placed in the supply line near to the stop valve on each container. If a change-over device is used (automatic or manual), it should be provided with non-return valves to isolate any depleted container.
- 3.3 Where more than one container can supply a system, the system should not be used with a container removed, unless the unattached pipe is fitted with a suitable gas tight plug arrangement.
- 3.4 Containers not in use or not being fitted into an installation should have the protecting cap in place over the container valve.

## **4 Fittings and Pipework**

- 4.1 For rigid pipework systems solid drawn copper alloy or stainless steel tube should be used. Steel tubing, aluminium, or any materials having a low melting point should not be used.
- 4.2 Connection between rigid pipe sections should be made with, hard solder (minimum melting point 450°C). Appropriate compression or screwed fittings are recommended for general use for pipework in LPG installations.
- 4.3 Lengths of flexible piping (if required for flexible connections) should conform to an appropriate standard, be kept as short as possible, and be protected from inadvertent damage. Such hose should be installed in such a manner to allow access for inspection along its length.

Proposals for a more extensive use of flexible piping (which conforms to an internationally recognised standard for its application) should be submitted to the Administration for approval on an individual basis.

## **5 Appliances**

- 5.1 All appliances should be well secured to avoid movement.
- 5.2 All unattended appliances should be of the room sealed type, i.e where the gas flames are isolated in a totally enclosed shield where the air supply and combustion gas outlets are piped to open air.
- 5.3 All gas burners and pilot flames should be fitted with a flame supervision device which will shut off the gas supply to the burner or pilot flame in the event of flame failure
- 5.4 Flue-less heaters should be selected only if fitted with atmosphere-sensitive cut-off devices to shut off the gas supply at a carbon dioxide concentration of not more than 1.5% by volume.
- 5.5 Heaters of a catalytic type should not be used.

## **6 Ventilation**

- 6.1 The ventilation requirements of a space containing a LPG appliance should be assessed against an appropriate standard and should take into account gas burning equipment and persons occupying that space.
- 6.2 Where ventilators required for LPG appliances in intermittent use can be closed, there should be appropriate signs at the appliance warning of the need to have those ventilators open before the appliance is used.

## **7 Gas Detection**

- 7.1 Suitable means for detecting the leakage of gas should be provided in any compartment containing a gas-consuming appliance, or in any adjoining space of a compartment into which the gas (more dense than air) may seep.
- 7.2 Gas detectors heads should be securely fixed in the lower part of the compartment in the vicinity of the gas-consuming appliance and in other space(s) into which gas may seep.

In areas where the detector head is susceptible to damage in the lowest part of the compartment (e.g. engine space bilge) the detector head should at least be fitted below the lowest point of ignition.

7.3 Any gas detector should preferably, be of a type which will be actuated promptly and automatically by the presence of a gas concentration in air of not greater than 0.5% (representing approximately 25% of the lower explosive limit). The detection system should incorporate a visible alarm and an audible alarm which can be heard in the space concerned and the control position with the vessel in operation.

7.4 Where electrical detection equipment is fitted, it should be certified as being flame-proof or intrinsically safe for the gas being used.

7.5 In all cases, the arrangements should be such that the detection system can be tested frequently whilst the vessel is in service, which should include a test of the detector head operation as well as the alarm circuit, in accordance with the manufacturer's instructions.

7.6 All detection equipment should be maintained in accordance with the manufacturer's requirements.

## **8 Emergency Action**

8.1 A suitable notice, detailing the action to be taken when an alarm is given by the gas detection system, should be displayed prominently in the vessel.

8.2 The information given should include the following:

- .1 The need to be ever alert for gas leakage; and
- .2 When leakage is detected or suspected, all gas-consuming appliances should be shut off at the main supply from the container(s) and NO SMOKING should be permitted until it is safe to do so.
- .3 **NAKED LIGHTS SHOULD NEVER BE USED AS A MEANS OF LOCATING GAS LEAKS.**

**ANNEX 4 LIST OF CERTIFICATES TO BE ISSUED**

<b>Certification</b>	<b>Subject &amp; Convention</b>	<b>Limits</b>	<b>Detail &amp; Remarks</b>
International Tonnage Certificate	Tonnage ITC 69	≥ 24 metres	
International Load Line Certificate	Load Line ILLC'66	≥ 24 metres	Intact Stability & Subdivision Standard <sup>6</sup>
Cargo Ship Safety Construction Certificate	Construction SOLAS 74	≥500GT	Construction <sup>1</sup>
	Fire Protection SOLAS 74	≥500GT	Structural Fire Protection & Means of Escape <sup>1</sup>
Cargo Ship Safety Equipment Certificate	Fire Appliances SOLAS 74	≥500GT	Fire Appliances <sup>1</sup>
	Life Saving Appliances SOLAS 74	≥500GT	Life – Saving Appliances <sup>1</sup>
	Navigation Equipment SOLAS 74	≥500GT	Navigation lights, sounds, signals <sup>1</sup> etc
Cargo Ship Safety Radio Certificate	Radio SOLAS 74	≥300GT	Communications
Safe Manning Document	Manning STCW 95	≥500GT	Manning <sup>1</sup>
International Oil Pollution Prevention Certificate	Pollution MARPOL Annex I	≥400GT	Oil Pollution Prevention Equipment
International Sewage Pollution Prevention Certificate	Pollution MARPOL Annex IV	≥400GT >15 persons	Sewage Pollution Prevention
International Air Pollution Prevention Certificate/EIAPP	Pollution MARPOL Annex VI	≥400GT >130kw	Air Pollution Prevention
Anti-Fouling System Certificate of Compliance		≥400GT	Hull Anti-Fouling
Safety Management Certificate	International Safety Management Code	≥500GT	Operations <sup>1</sup>
International Ship Security Certificate	International Ship and Port Facility Security Code	≥500GT	Security <sup>1</sup>
Maritime Labour Certificate	Maritime Labour Convention 2006	≥500GT	Seafarer Living & Working Conditions. (Recommended for <500GT) <sup>1</sup>
Certificate of Compliance	Various	≥24 metres	Covers aspects surveyed under the code for which other certificates are not required. <sup>1</sup>

<sup>6</sup> The Administration retains the right to survey and issue certificates for this item

## ANNEX 5 UNITED KINGDOM NATIONAL ANNEX

For United Kingdom vessels, this Code of Practice is enabled by The Merchant Shipping (Vessels in Commercial Use for Sport or Pleasure) Regulations 1998 SI 1998/2771, as amended.

The annex contains requirements and supplementary notes specific to United Kingdom vessels. These are referenced under the same section numbers as they would appear in the main Code text.

### 2 Definitions

"Aviation Inspection Body" for United Kingdom [see MGN 433 for a link to List of current approved bodies](#).

"Merchant Shipping Notice", "Marine Guidance Notes" and Marine Information Notes means Notices/Notes described as such and issued by the Maritime and Coastguard Agency; and any reference to a particular Notice/Note includes a reference to any document amending or replacing that Notice/Note which is considered by the Secretary of State to be relevant from time to time and is specified in a Merchant Shipping Notice/Note;

"Minimum Age of Trainees"

A trainee may only sail on a vessel in which it can reasonably be expected] that he or she is physically and mentally capable of safely taking part in the operation of the vessel. There shall be specific documented provisions in place to cover the health, safety, and welfare of the trainees. Safety management tools, such as formal safety assessment (FSA) techniques may be useful when considering the acceptable age of a trainee for a specific vessel, voyage or operating area/condition. Due consideration must also be given to the profile and balance of the crew for each voyage taking into account the age and sex of the trainees. In any event a trainee shall not be less than 12 years of age and any person below this age must be considered as a passenger.

"pleasure vessel" has the same meaning as in The Merchant Shipping (Vessels in Commercial Use for Sport or Pleasure) Regulations 1998 SI 1998/2771, as amended, as follows.

"pleasure vessel" means

- (a) any vessel which at the time it is being used is:
  - (i) (aa) in the case of a vessel wholly owned by an individual or individuals, used only for the sport or pleasure of the owner or the immediate family or friends of the owner; or
    - (bb) in the case of a vessel owned by a body corporate, used only for sport or pleasure and on which the persons on board are employees or officers of the body corporate, or their immediate family or friends; and
  - (ii) on a voyage or excursion which is one for which the owner does not

receive money for or in connection with operating the vessel or carrying any person, other than as a contribution to the direct expenses of the operation of the vessel incurred during the voyage or excursion; or

- (b) any vessel wholly owned by or on behalf of a members' club formed for the purpose of sport or pleasure which, at the time it is being used, is used only for the sport or pleasure of members of that club or their immediate family, and for the use of which any charges levied are paid into club funds and applied for the general use of the club; and
- (c) in the case of any vessel referred to in paragraphs (a) or (b) above no other payments are made by or on behalf of users of the vessel, other than by the owner.

In this definition "immediate family" means-

in relation to an individual, the spouse or civil partner of the individual, and a relative of the individual or the individual's spouse or civil partner; and "relative" means brother, sister, ancestor or lineal descendant;

"To Sea" means beyond Category D Waters, or Category C waters if there are no Category D waters.

### **3 Application and Interpretation**

3.1.1 This revision of the Code comes into effect on 1<sup>st</sup> January 2012 and replaces "The Code of Practice for the Safety of Large Commercial Sailing and Motor Vessels" published in 1997. Vessels certificated to the requirements of the original Code may continue to operate under the same provisions applicable at the time of certification. Vessels undergoing refit or modification are encouraged to comply with the provisions of this revision as far as is reasonable and practicable.

The application of the 3000GT limit is not applicable to vessels for which the building contract is signed, or survey has started, prior to 24th September 2004.

3.1.1.1 A coded vessel chartered or operated commercially, for the purpose of racing need not comply with the provisions of the Code whilst racing, or whilst in passage directly to or from a race, provided that the vessel complies with the following:-

.1 It complies with the racing rule provisions of either the International Sailing Federation (ISAF) or the Union Internationale Motonautique (UIM).

.2 It complies with the racing rule provisions of the affiliated Member National Authority, of either the ISAF or UIM, in the country where the race takes place.

.3 It complies with the safety rule provisions of the race Organising Authority affiliated to the Member National Authority and thereby recognised by the ISAF or UIM to organize races in the country where the race takes place.

.4 If it is a yacht racing offshore, it complies with the appropriate parts of the ISAF Offshore Racing Committee's special regulations or the similar requirements of the affiliated race Organising Authority.

.5 When on charter and in passage to and from the race, the race or equivalent safety cover shall be in force, or the vessel is to be in its coded condition for the

passage.

The relief from compliance with the provisions of the Code which is permitted by Section 3.1.1.1 does not apply to a vessel taking part in an event created and organised with the intent to avoid the provisions of the Code.

Notes:

1. Only clubs recognised by an ISAF Member National Authority (MNA) may use the ISAF racing rules. In the UK this means a club affiliated as a club to the RYA. (This does not include RYA recognised teaching establishments).

2. The UIM racing rules require all racing drivers to have been licensed by a UIM MNA. In the UK, the RYA issues such licences, which require pre medical examinations and minimum levels of past experience.

3. All legitimate races are required, by the ISAF or UIM rules, to have been “pre-advertised” by means of a Notice of Race and be controlled by Sailing or Race Instructions. The minimum provisions for these are set out in the ISAF and UIM racing rules.

### **3.2.2 Exemptions**

For Coded vessels while operating as pleasure vessels, the MCA may issue an exemption to regulations applicable to UK passenger ships subject to a maximum of 36 guests being carried, sufficient life-saving appliances, and a Safe Manning Document (including vessels under 500GT) being in force. Applications will be considered on a case by case, and voyage by voyage basis.

## **4 Construction and Strength**

### **4.3.1 Classification Societies**

American Bureau of Shipping  
Bureau Veritas  
Det Norske Veritas  
Germanischer Lloyd  
Lloyds Register  
Nippon Kaiji Kyokai  
Registro Italiano Navale

## **22 Protection of Personnel**

22.3.1 Reference should be made to the Code of Safe Working Practices for Merchant Seamen.

### **22.5 Noise**

MSN 1763 "The Merchant Shipping and Fishing Vessels (Safety Signs and Signals) Regulations 2001" provides details of required safety signs.

## **23 Medical Stores**

Medical stores requirements are contained within MSN 1768 "Ship's Medical Stores".

### **24.5 Submersible craft**

Registration, construction and operation of submarines are regulated by the following United Kingdom Statutory Instruments:

SI No.940 The Merchant Shipping (Registration of Submersible Craft) Regulations 1976, as amended.

SI No.1098 The Merchant Shipping (Submersible Craft Construction and Survey) Regulations 1981.

SI No.311 The Merchant Shipping (Submersible Craft Operations) Regulations 1987.

## **25 Clean Seas**

The IMO MARPOL Convention Annexes relevant to the operation of Large Yachts are implemented by the following United Kingdom Statutory Instruments;

**SI 1996 No. 2154 "Merchant Shipping (Prevention of Oil Pollution) Regulations" as amended.**

**SI 2008 No. 3257 "Merchant Shipping (Prevention of Pollution by Sewage and Garbage) Regulations", guidance on which is contained in MSN 1807 and MGN 385.**

SI 2003 No. 1809 "Merchant Shipping and Fishing Vessels (Port Waste Reception Facilities) Regulations". **Information on these requirements can be found in MGN 387.**

SI 2008 No. 2924 "Merchant Shipping (Prevention of Air Pollution from Ships) Regulations 2008". Information on these requirements can be found in MSN 1819, MGN 381, MGN 386, and MGN 400.

26

## Manning

In addition to unrestricted STCW qualifications, information as to specific qualifications for Large Yachts and Sail Training Vessels are contained within:

MGN 156 "Training and Certification Guidance – Part 17 Certificates of Competency or Marine Engine Operator Licences for Service as an Engineer Officer on Commercially and Privately Operated Yachts and Sail Training Vessels", and;

MSN 1802 "Training and Certification Guidance - Part 21 Deck Officer Certificates of Competency For Service on Commercially and Privately Operated Yachts and Sail Training Vessels".

MGN 270 "Training and Certification Guidance – Part 23 – Yacht Rating Certificates for service on commercially and privately operated yachts and sail training vessels".

A training organisation wishing to operate UK registered Training Vessel(s) **carrying more than 12 trainees** must register this intention with the Maritime and Coastguard Agency (MCA) including details of:

- 1 The organisation together with points of contact
- 2 Name, port of registry, size and type of vessel;
- 3 Details of the regular crew. This may be evidenced by a safe manning document. However, in the absence of a safe manning document this should be in the form of a declaration of the minimum manning required for contracted crew as detailed in MSN 1767 (or as subsequently amended).
- 4 Maximum number of trainees that can be carried;
- 5 The age profile of the trainees; and
- 6 Any special circumstances relevant to the proposed operation.

If operating under a Code then the vessel's Code Certificate of Compliance should be endorsed 'Sail Training Vessel' or 'Motor Training Vessel'.

Every vessel shall have a Risk Assessment and Safety Policy in place. If trainees under the age of 18 are to be carried they shall also have a Child Protection policy and appropriate code of conduct to ensure the welfare and well being of the trainees.

The registration will only be approved provided the proposal fully satisfies the recommendations and guidelines outlined above. The MCA may require an owner or operator to amend a proposal if, after evaluation, the proposal is considered inadequate.

[A training vessel may carry a combination of passengers and trainees. However, a training vessel operating under a Code of Practice may only carry a maximum of 12 passengers at any time.]

**28 Survey, Certification, Inspection, and Maintenance**

The list of UK Certifying Authorities for radio installations is listed in MGN 392. For classed vessels, radio survey is delegated to classification societies.

**29 Accident Investigation Reporting Regulations**

Under "The Merchant Shipping (Accident Reporting and Investigation) Regulations" 2005, SI No. 881, it is a requirement to report accidents and hazardous events to the Department for Transport's Marine Accident Investigation Branch. Guidance is available in MGN 289 "Accident Reporting and Investigation".

**30 Crew Agreements**

Crew Agreements should be as detailed in MGN 149.

**Table 1 - List of Certificates to be issued to United Kingdom Ships, applicable UK Regulations and extent of Delegation**

<b>Certification</b>	<b>Subject &amp; Convention</b>	<b>Limits</b>	<b>Detail &amp; Remarks</b>	<b>UK Regulation</b>	<b>Delegation</b>
International Tonnage Certificate	Tonnage ITC 69	≥ 24 metres		Merchant Shipping (Tonnage) Regulations 1997 SI No. 1510, as amended	Classification Societies
International Load Line Certificate	Load Line ILLC'66 General		Intact Stability & Subdivision Standard; # - Using equivalent standards of the Code	Merchant Shipping (Load Line) Regulations 1998 SI No. 2241, as amended	Assigning Authorities <sup>1</sup>
	Inclining Test, Stability	≥ 24 metres			MCA
Cargo Safety Construction Certificate	Construction SOLAS 74	≥ 500GT	Construction	Merchant Shipping (Cargo Shipping Construction) Regulations 1997, SI No. 1509, as amended	Certifying Authorities <sup>1</sup>
	Fire Protection SOLAS 74	≥ 500GT	Structural Fire Protection & Means of Escape - Using the equivalent standards of the Code	Ships constructed before 1 July 2002: Merchant Shipping (Fire Protection-Large Ships) 1998 Regulations SI No. 1012, as amended. Ships constructed on or after 1 July 2002. Merchant Shipping (Fire Protection) Regulations 2003, SI No. 2950, as amended.	Certification issued by Certifying Authorities <sup>1</sup> on a partial declaration by MCA on Structural Fire Protection, Means of Escape, Fire Safety of Unattended Machinery Spaces and Accommodation etc
Cargo Safety Equipment Certificate	Fire Appliances SOLAS 74	≥ 500GT	Fire Appliances		MCA
	Life Saving Appliances SOLAS 74	≥ 500GT	Life Saving Appliances	Merchant Shipping (Life Saving Appliances (Ships Other than Ships of Class III to VI(A))) Regulations 1999 SI No. 2721, as amended.	
	Navigation Equipment SOLAS 74	≥ 500GT	Navigation lights, sounds, signals etc	Merchant Shipping (Distress Signals and Prevention of Collisions) Regulations 1996, SI No. 75, as amended.	

<sup>1</sup> Classification Societies, Assigning Authorities and Certifying Authorities for Large Yachts means one of the six Classification Societies accepted by the Maritime & Coastguard Agency: American Bureau of Shipping, Bureau Veritas, Det Norske Veritas, Germanischer Lloyd, Lloyds Register of Shipping and Registro Italiano Navale

<b>Certification</b>	<b>Subject &amp; Convention</b>	<b>Limits</b>	<b>Detail &amp; Remarks</b>	<b>UK Regulation</b>	<b>Delegation</b>
Cargo Safety Radio Certificate	Radio SOLAS 74	≥ 300GT		Merchant Shipping (Radio Installations) Regulations 1998 SI No. 2070, as amended.	Authorised persons. <sup>1</sup>
Safe Manning Document	Manning STCW 95	≥ 500GT		Merchant Shipping (Safe Manning, Hours of Work and Watchkeeping) Regulations 1997 SI No. 1320, as amended.	MCA
International Oil Pollution Prevention Certificate	MARPOL Annex I	≥ 400GT	Pollution prevention equipment	Merchant Shipping (Prevention of Oil Pollution) Regulations 1996 SI No. 2154, as amended.	Classification Societies <sup>1</sup>
International Air Pollution Prevention Certificate	MARPOL Annex VI	≥ 400GT ≥ 130kw		Merchant Shipping (Prevention of Air Pollution from Ships) Regulations SI 2008 No. 2924.	Classification Societies <sup>1</sup>
International Sewage Pollution Prevention Certificate	MARPOL Annex IV	≥ 400GT > 15 persons		Merchant Shipping (Prevention of Pollution by Sewage and Garbage) Regulations SI 2008 No. 3257.	Classification Societies <sup>1</sup>
Safety Management Certificate	International Safety Management Code	≥ 500GT		<b>The Merchant Shipping (International Safety Management (ISM) Code) Regulations 1998 SI 1998 No. 1561 as amended.</b>	MCA
International Ship Security Certificate	International Ship and Port Facility Security Code	≥ 500GT		<b>The Ship and Port Facility (Security) Regulations 2004 SI 2004 No. 1495 As amended</b>	MCA
Certificate of Compliance	Various	≥24 metres	Covers aspects surveyed under the code for which other certificates are not required.	Merchant Shipping (Vessels in Commercial Use for Sport and Pleasure) Regulations 1998 SI No. 2771, as amended.	MCA

**ANNEX 6 TECHNICAL STANDARD FOR HELICOPTER LANDING AREAS**

For environmental considerations and to minimise the size of LY2 Edition 3, the contents of Annex 6 have been removed but are available as Amendment 1 to MSN 1792 in a separate Merchant Shipping Notice.

The content remains the same as in Edition 2.

## **ANNEX 7**